



# ***SUPERIDE***

## **INSTALLATION INSTRUCTIONS 1932 FORD INDEPENDENT FRONT SUSPENSION**

Please read these instructions *completely*  
before starting your installation.  
Remember the basic rule for a successful installation:  
**Measure Twice, Weld Once.**

For questions on installations please call 800-841-8188 In Illinois (847) 487-0150



**You are about to install your HEIDTS suspension system. You are probably wondering how complicated installing a complete IFS system really is, with all those pieces, all the angles, anti-dive, geometry...Don't worry. The HEIDTS I.F.S. kits are designed so all that is taken care of for you. Just follow the instructions step by step and in a very short time your car will be sitting on the nicest riding I.F.S. kit available. Your car may be using stock frame rails or you may be using new reproduction boxed rails. If you are using new boxed rails, you may skip to Step 4. If you are using stock rails, you can proceed from here.**

1. First, remove all the stock components. Any suspension brackets, steering or shock brackets that are welded to the frame should be taken off and ground smooth.

2. The stock crossmember will need to be removed next. In order to hold the rails in place, a temporary brace can be clamped or tack welded across the rails. Drill out the rivets and remove the crossmember. The rivet holes can then be welded up and ground smooth.

3. Boxing the rails is next. The rails should be squared up as far as the flanges are concerned and made straight and true. The boxing plates are then placed up against the rails and clamped in place. Weld short sections at a time in alternating locations to minimize warpage. Grind smooth when done.

4. Mark the axle centerline. On the 32 Ford it is located 13-1/4" back from the center of the front spreader bar hole, as shown in **Figure 1**. Mark this line on the top of the frame, as it is used for a couple of measurements.

5. Trial fit the new crossmember onto the rails. It should be located with its centerline 118" forward of the marked axle centerline. See **Figure 2**. The caster setting will bring the spindle pin back in line. The frame is 25-3/4" wide at the axle centerline. During boxing, the rails may have a tendency to bow outward slightly if they were clamped ahead of the axle centerline. Pull the rails in to fit the crossmember up onto the rails. It should be seated flat against the bottom of the frame rails. Clamp in place, double check your measurements, making sure crossmember is squared on the frame, then weld in place. Weld all around, top, sides and bottom. This crossmember keeps the front frame rails from twisting and flexing, so good strong welds are required.

6. The radiator tabs are next. They are located 3/4" forward of the axle C/L and 1/2" below the top of the frame, as shown in **Figures 3A & B**. Clamp in place, then weld all around.

7. Now assemble all the suspension components. *Note: The shim washers supplied may be needed to center the calipers on the rotors. Do not install the coil-over assemblies just yet. Position the car at approximately the ride angle or rake that the car will sit at when finished. Prop up the lower control arms so the center of the lower ball joint housing is 3/4" above the centerline of the inner pivot bolt. This is the designed midpoint of the suspension system.* Now set the caster, camber and toe-in. The settings are as follows:

For questions on installations please call 800-841-8188 In Illinois (847) 487-0150



CASTER 1° positive

CAMBER 1/4° positive

TOE-IN 1/8 + 1/8

The caster and camber settings are done with the adjusters in the upper control arms. Both adjusters are screwed in or out an equal amount to change the camber, and they are adjusted opposite each other to change caster. Approximately 1° of caster is built into the crossmember already, so not much change is required there. The interesting thing about the caster setting is that you can experiment with different settings and actually “tune” the characteristics of the handling of your car to your driving style. 1° of caster will give a nice road feel and good low speed drivability. 2° or 3° will yield better high speed stability and tracking, putting a better self-centering characteristic in the steering wheel, but will tend to start to make parking slightly more difficult. Have fun with this one, as it truly makes your car your own car. Just be sure that both sides have equal caster settings, or the car will tend to pull to one side.

8. Next relax the suspension and install the coil-overs. The spring seat rings should be in the bottom position, providing the least amount of preload. The car should now be placed on the ground. The spring seat rings should be adjusted to position the ride height of the suspension to that same 3/4” dimension referred to in Step 7. Make sure that at this point you are working with a finished, fully weighted car, not just a frame, or a frame and body. At this point do a quick double check of your alignment.

9. Since you are now to the point where you have a finished, running car (we hope!) it is time to test drive it. After a few hundred miles, double check the ride height and the alignment. The springs may have settled which would change the camber setting. Readjust the ride height before changing the alignment. After this initial settling period, the springs and bushings should have taken their final set, so you should be on your way to many miles of cruising in style, independently.

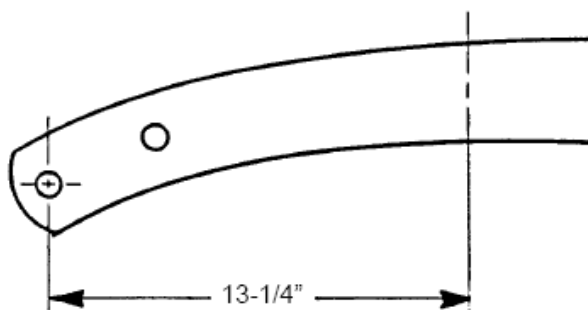

Measure Straight Back

**Figure 1-** Axle Centerline

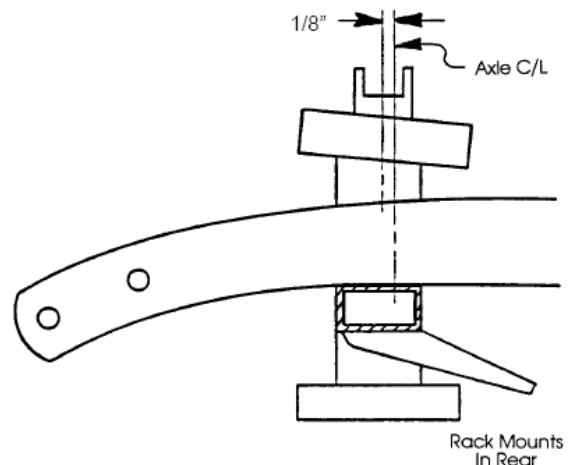

**Figure 2-** Crossmember Trial Fit

For questions on installations please call 800-841-8188 In Illinois (847) 487-0150



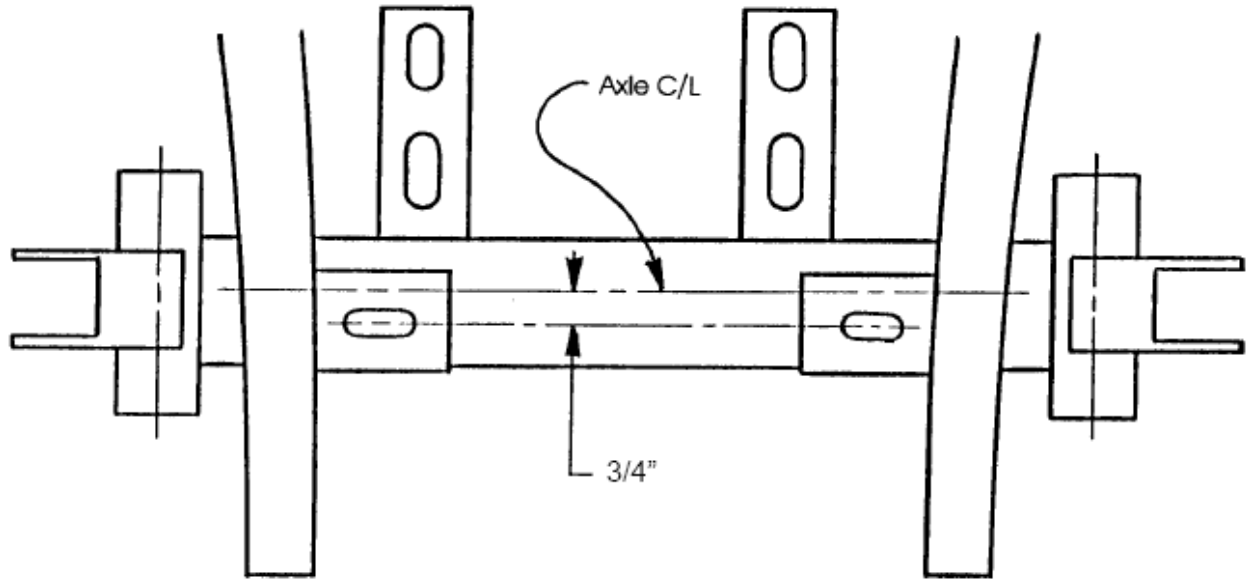

**Figure 3A-** Radiator Tabs

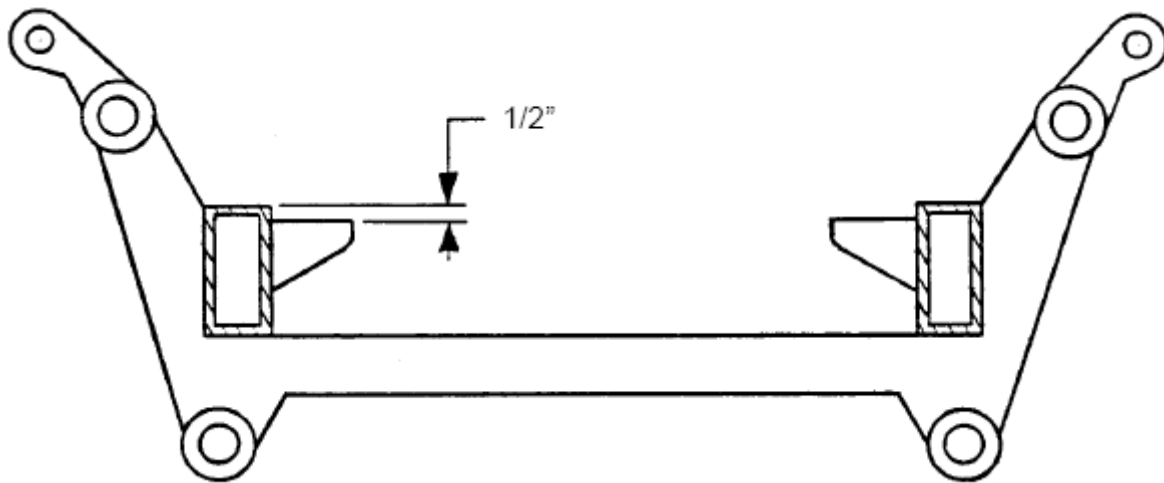

**Figure 3B-** Radiator Tabs

For questions on installations please call 800-841-8188 In Illinois (847) 487-0150

