



RC-101-WT

INSTALLATION INSTRUCTIONS

67-69 Camaro

4-Link Kit



Please read these instructions completely before starting your installation.
Remember the basic rule for a successful installation:

****** Measure Twice, Bolt-in Once. ******

******Do Not Paint or Powder Coat any suspension components before trial fitting all items ******

****** This kit lowers vehicle approximately 2"-3" ******

For questions on installations please call 800-841-8188 In Illinois (847) 487-0150



HARDWARE LIST

PART NO	DESC.	QTY.	
1	HD-011	½-13 NYLOCK NUT	16
2	HD-047	½-20 X 2 ½ HEX	2
3	HD-049	3/8-16 X 1 HEX	4
4	HD-048	½-20 NYLOCK NUT	2
5	HD-066	5/8 NYLOCK NUT	4
6	HD-067	5/8 WASHER	2
7	HD-080	5/16 X ¾ HEX	2
8	HD-082	5/16 WASHER	6
9	HD-084	½ X 13 X 2 ½ HEX	1
10	HD-108	5/8-18 X 2 ¾ HEX	6
11	HD-109	5/8-18 NYLOCK NUT	8
12	HD-135	½ - 13 X 1 ¾ HEX	6
13	HD-137	½ -13 X 3 HEX	11
14	HD-157	5/8-11 X 3 HEX	2
15	HD-223	5/8-11 X 7 HEX	2
16	HD-231	5/8-18 X 4 ½ HHCS	2
17	RB-009	COIL OVER MOUNT SPACER	2
18	RC-094	LOWER LINK SPACER SHORT	2
19	RC-095	LOWER LINK SPACER LONG	2

- 1) Start your installation by removing the rear seat. Jack up the car and support it on sturdy jack stands. Remove the drive shaft, e-brakes cables and rear axle assembly including leaf springs and shocks. If the brakes will be reused, the lines can be left connected to the backing plates depending on what type of axle will be used.
- 2) Remove the rear section of the exhaust system. Also remove the front leaf spring mounts, as they will be modified and reused. If using mini-tubs, install per instructions. First remove the bump stop mounts from the frame.
- 3) Install the top saddles up onto the frame rails under the floor, see figure 1 **Error! Reference source not found.** The saddles locate using the holes from the bump stop brackets. The brackets are slotted – On the driver’s side, the bolts should be at the front of the slots, on the passenger side the bolts should be at the top of the slots. The saddles are located 18-3/4” from the back of the saddle brackets to the center of the rear shackle hole. **Note:** If you have a 1967, there are no holes on the side of the frame rail, so use the dimension above to locate the brackets. The U-channel must be firmly seated against the bottom of the sub-frame rail. Drill the 1/2” dia. holes through the factory frame rails using the cross-member end plates as templates and bolt securely in place.

For questions on installations please call 800-841-8188 In Illinois (847) 487-0150



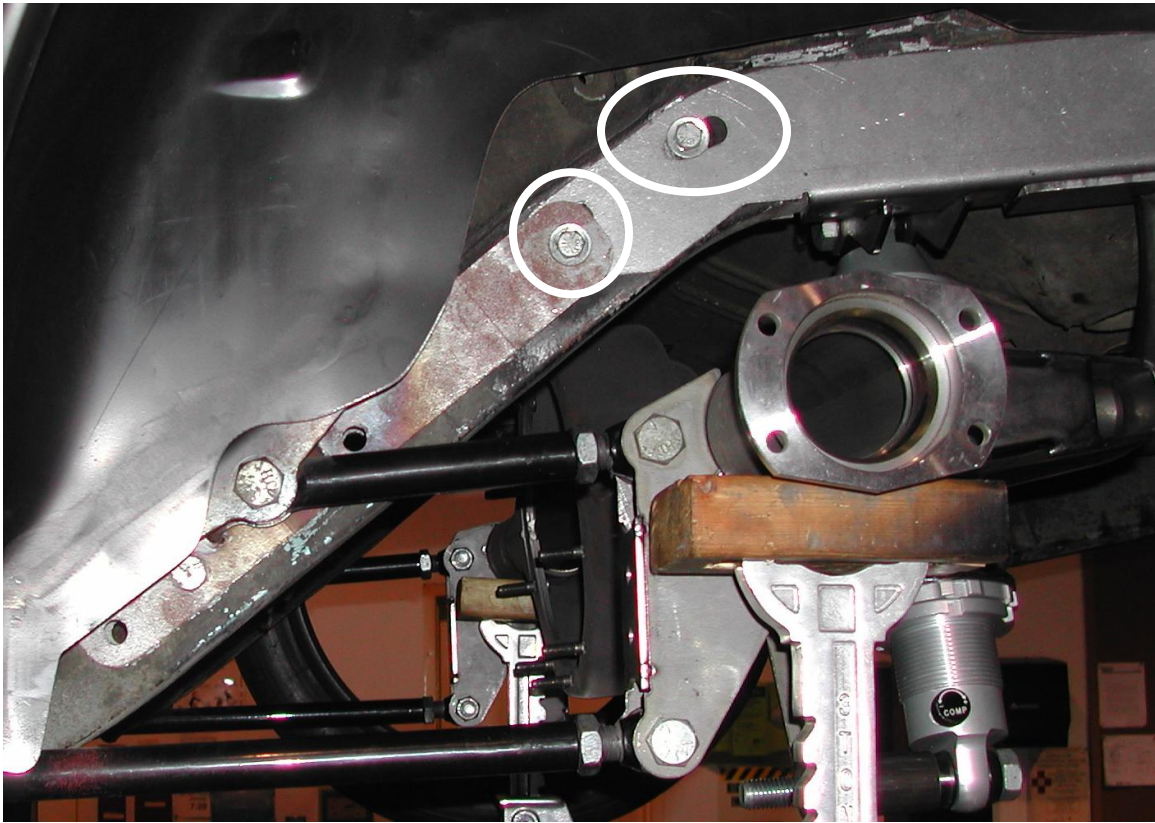

Figure 1. Driver side frame rail brackets, note bolt location in front of slots (circled)



Figure 2. Passenger side frame rail brackets, note bolt location in top of slots (circled)

For questions on installations please call 800-841-8188 In Illinois (847) 487-0150



- 4) Install the upper link brackets next. They are located using the front holes on the ends of the top cross-member plates on the front factory frame rails. Drill through the floor and using the backing plates inside the car, under the seat, sandwich the floor pan and bolt in place. Then drill 1/2" holes through the factory frame rails and bolt the sides of the front mounts using the reinforcement plates in the inner side of the rails, see **Error! Reference source not found.** The upper links may be installed now, with the adjusters on the rear (axle side).
- 5) Install the lower links into the factory front leaf spring mount. The holes will need to be drilled out to 5/8" dia. for the front 4-link bolts. Once they are drilled, they can be installed and bolted in place. The lower links use spacers at the inside and outside of the link in the leaf spring mount, with the outside spacer being slightly longer than the inside spacer. See
- 6) Figure 3.

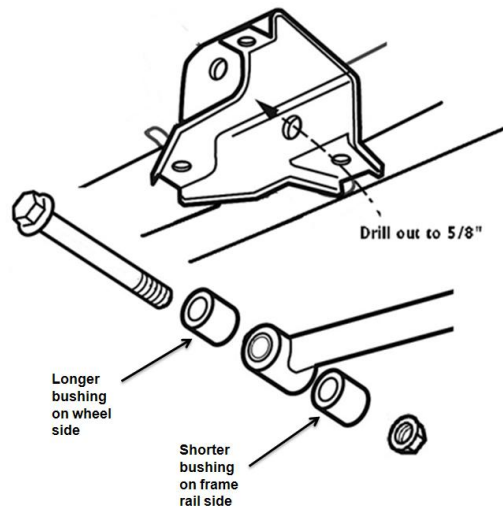
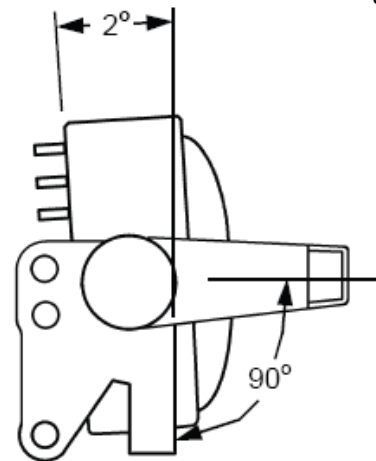

Figure 3. Lower Link Chassis Mount (Driver Side)

- 7) If you purchased a complete rear axle housing with the brackets already installed, you can install it now. If you are installing the brackets on your own housing, the coil-over brackets are located 40-1/4" apart. They are centered equal distance from the outer ends of the housing, not



from the center of the third member or pinion yoke, see

- 8) Figure 4. Sway bar tabs are located 21" apart with a 1/2" gap and 5/8" below axle centerline. The Panhard bar bracket is located on the left coil-over bracket locating against the coil-over bracket, positioned at 90° as shown in s (Front View) Figure 5.

For questions on installations please call 800-841-8188 In Illinois (847) 487-0150



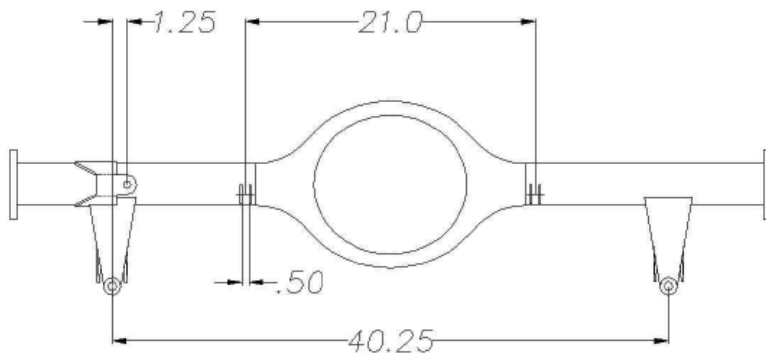

Figure 4. Axle brackets (Front View)

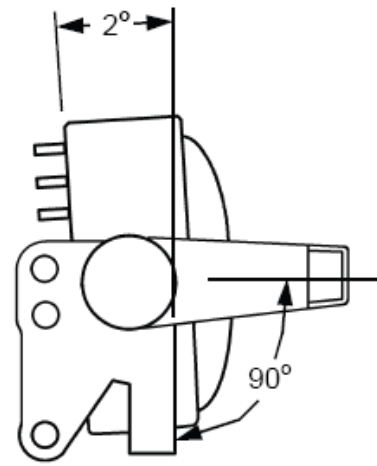

Figure 5. Axle Brackets (Driver Side View)

- 9) Position the rear axle housing in place and install the links into the brackets on the housing. Install the 5/8-18 bolts and nuts hand tight. Assemble the coil springs onto the shock assemblies and install them into the upper mounts using the 5/8-18 x 2-3/4" bolts and nuts, and onto the housing using the 5/8-11 x 7" bolts, spacers and nuts supplied, and tighten down. Now install the Panhard Bar using the 1/2-13 bolts and nuts supplied, and keep it hand tight so the Panhard can be adjusted.
- 10) Install the brakes, wheels/tires onto the axle and lower the car down onto level ground. Adjust the coilovers to set the desired ride height. Now, with the car on level ground, adjust the Panhard bar until the axle is centered on the car. This can be measured at the wheel/fender lip surfaces or between the frame rail and fender lip.
- 11) With 1 upper link disconnected, adjust the lower links evenly to the proper wheelbase, and use the upper bar to fine tune the pinion angle to 2° down, refer to s (Front View) Figure 5. Once set, adjust the second upper bar to the proper length, swing in place – the bolt should slide right in. Double check all angles, then tighten down all bolts and nuts, including jam nuts.
- 12) Next, install the bump stop rubbers onto the cross-member mounts. Connect the brake lines and bleed the brakes and then install the drive shaft and emergency brake cables.



Figure 6. Rear view of assembled 4-Link Kit

For questions on installations please call 800-841-8188 In Illinois (847) 487-0150

