

Installation Instructions

'67-'69 CAMARO / FIREBIRD, '68-'74 NOVA, '64-'72 CHEVELLE

HIGH PERFORMANCE 2" DROPPED TALL SPINDLES

Please read these instructions completely **BEFORE** starting your installation!

Begin installation of your HEIDTS 2" Dropped Tall Spindles by placing the Spindles on the lower control arm ball joints and assemble ball joint nuts. Insert the upper control arm ball joints into Spindles and assemble nuts. Install your old steering arms onto the spindles using the supplied 1/2-20 x 1-3/4" Gr. 8 bolts in the thin boss and the 1/2-20 x 2" Gr. 8 bolts in the thick boss of the steering arms onto the lower holes in the spindles as shown in Figure 1, using some form of Loctite compound. Install the tie rod ends into the steering arms next and assemble tie rod end nuts. Now tighten all the ball joint nuts and install the cotter pins.

Install your disc brake kit next. The HEIDTS HIGH PERFORMANCE Tall Spindles will accept any aftermarket disc brake kit made for stock spindles, or factory disc brake kit, but will require shorter bolts in the lower holes in the bracket. Brake kits purchased from HEIDTS contain these bolts. Install per their instructions. If factory caliper brackets and dust shields are used, **they require trimming**. See Figure 2. Drum brakes will not fit these spindles.

At this point, steer the Spindles from lock to lock with the suspension both up and down, checking the brake lines for adequate length. Make sure they are not pulled tight, or against anything. New, longer stainless steel lines may be required.

When installing wheels, check the clearance at the lower ball joints, lower control arm flanges and tie rod ends while again steering the Spindles from lock to lock. Tubular lower control arms are slimmer and have lower profile ball joints if more clearance is needed. Wheel spacers are another common item when using any Dropped Spindles. Remember that even though it is a direct bolt-on part, a Dropped Spindle is a different design spindle and compatibility of mating parts is the responsibility of the installer.

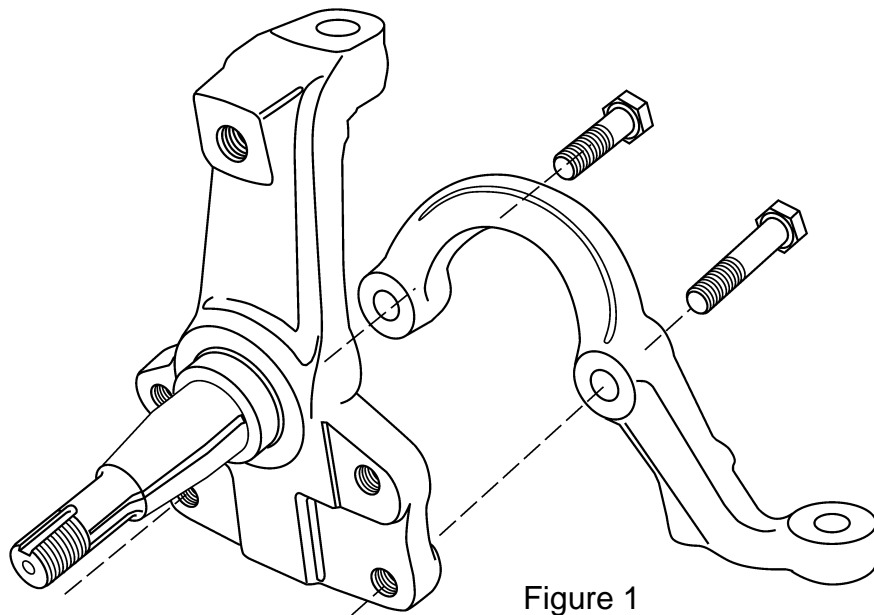

Figure 1

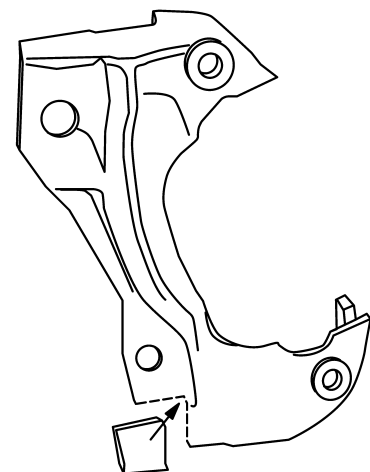

Figure 2

