

Installation Instructions

1932 FORD Rear Triangulated 4-Link Kit

*Please read these instructions completely **BEFORE** starting your installation!*

Your HEIDTS Hot Rod Shop 4-Link Kit contains the following items:

- | | |
|--------------------------|-------------------------|
| 2) Axle Brackets | 4) Axle Tabs |
| 2) Upper 4-Link Brackets | 4) Adjustable Link Bars |
| 2) Lower 4-Link Brackets | 1) 4-Link Hardware Kit |

(NOTE: Upper Crossmember, Coil-over Shocks and Hardware are Optional)

1. Begin by installing the Axle Brackets onto the housing. They are located 37" apart, as shown in Figure 1, and on the 2° angle shown in Figure 2, which is the pinion angle. Your pinion angle may not be 2°, but it must be determined at this time. Make sure that both Brackets are the same distance from the ends of the axle housing. The Axle Brackets should be tack welded to the housing, and the assembly double checked for square and correct pinion angle.
2. Position the axle housing in the frame at 27-1/4" forward measured from the rear frame hole as shown in Figure 3. Position the housing to set the pinion angle to match the angle of the engine which should place the rear coil-over mounts vertical. Assemble and install the Lower Link Bars, with the adjusters to the front, into the Axle Brackets on the housing using the 5/8-18 bolts and lock nuts supplied. Install the Front Lower Brackets and position against the inside of the boxed frame with the bolt center 2" below the frame. See Figure 3. Tack weld in place.
3. Assemble the Upper Link Bars with the adjusters to the front onto the Front Brackets and Axle Tabs. Position the Tabs on the axle housing with the bushing centers approximately 2" forward of the axle center as shown in Figure 3 and 16" apart as shown in Figure 4. The Front Brackets should be 1" below the top of the frame as shown in Figure 3. Tack weld in place. Check for floor pan clearance before final welding. If all is correct, remove the Link Bars and finish weld all brackets. Final welding should be performed by a qualified welder.
4. The pinion angle can be fine adjusted using the Lower Link Bars, see Figure 5. Install a coil-over shock crossmember per it's instructions, and install coil-overs onto the crossmember and axle housing brackets using a coil-over hardware kit.

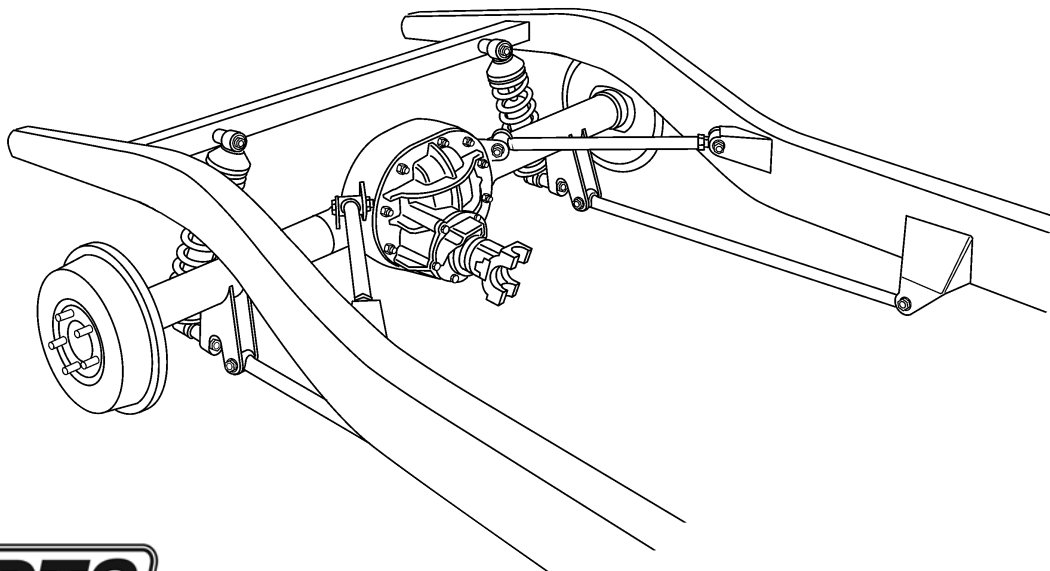

Installation Instructions

1932 FORD Rear Triangulated 4-Link Kit

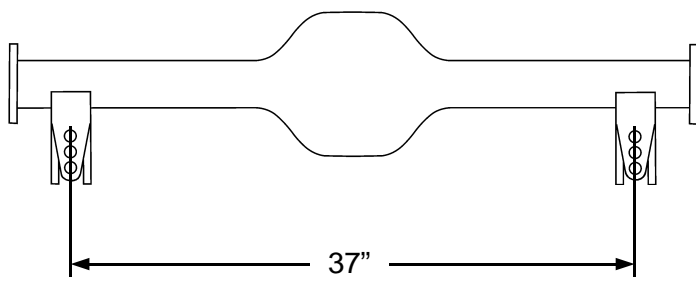

Figure 1

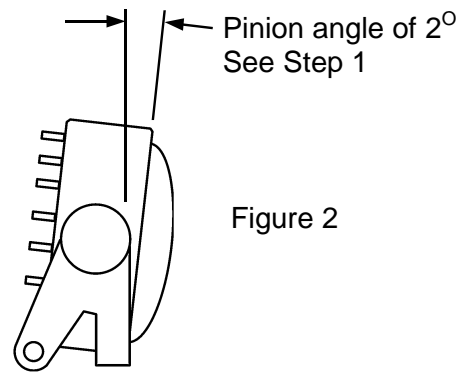

Figure 2

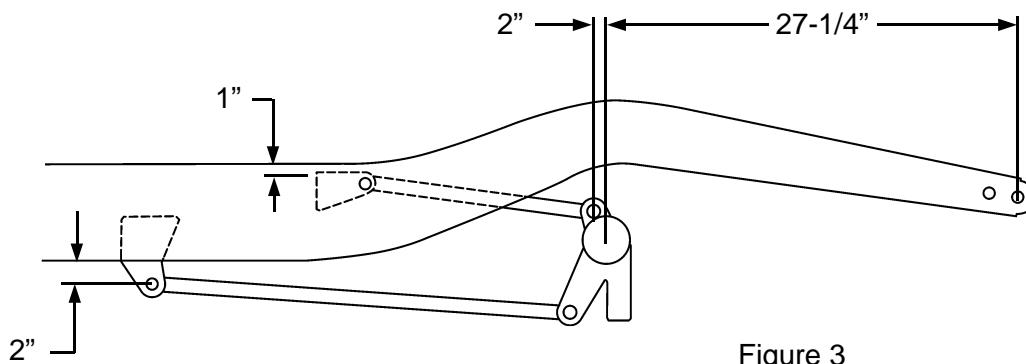

Figure 3

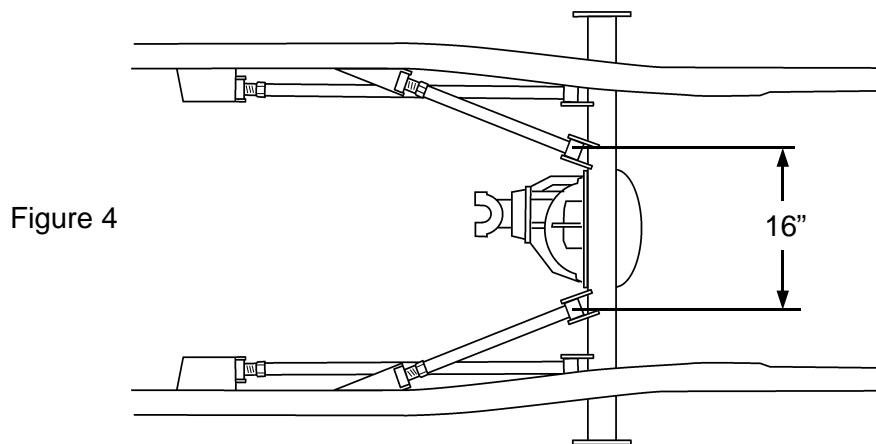

Figure 4

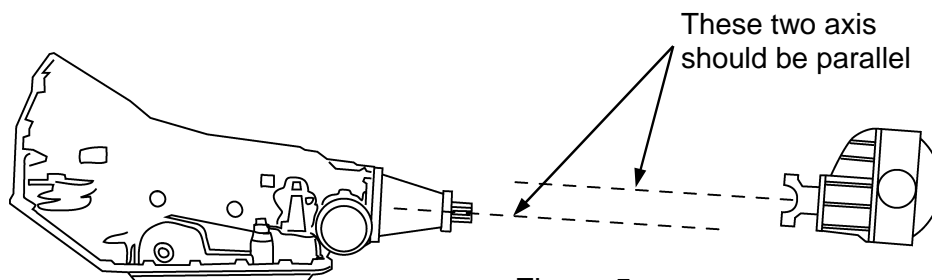

Figure 5