

Installation Instructions

STAINLESS TUBULAR COIL-OVER LOWER FULL A-ARMS

*Please read these instructions completely **BEFORE** starting your installation!*

Your HEIDTS Hot Rod Shop Stainless Tubular Lower Full A-Arms contains the following items:

- | | |
|---|---|
| 2) Stainless Lower A-Arms with Ball Joints and Bushings installed | 2) Stainless Inner Bushing Bolts & Nuts |
| 2) Ball Joint Boots | 6) Stainless Inner Bushing Washers |
| 2) Stainless Ball Joint Nuts & Cotter Pins | 2) Crossmember Spacers |
| 2) Stainless Ball Joint Nut Spacers | 2) Rear Spacers |
| 2) Stainless Lower Shock Bolts | 2) Gussets |

To begin installing your Mustang Lower A-Arms, the holes where the lower control arms attach to the Crossmember must be enlarged. Drill out the holes to 5/8". Mount the Crossmember Spacers and the Rear Spacers onto the Crossmember using the supplied Inner Bushing Bolts, Nuts and a temporary spacer under the Nuts. **DO NOT** use the A-Arms for this operation as the welding heat will melt the urethane bushings. Tighten the Bolts and Nuts tight. Weld the Rear Spacers to the Crossmember all around. Weld the Crossmember Spacers as far as possible on both ends. Position the Gussets horizontally, not vertically, against the Rear Spacers and the back of the Crossmember. Weld Gussets to Spacers and Crossmember. When they cool, remove the bolts and install the Lower A-Arms, using the Washers as shown. Tighten the bolts securely. Pull the A-Arms down and install the coil springs. Place a floor jack under the ball joints and raise the A-Arms enough to install the shocks, using the new Lower Shock Bolts supplied. Complete the assembly by installing the spindles, using the Ball Joint Nut Spacers under the Nuts **AS SHOWN, NOT** on the boots. Install Cotter Pins. **BE CERTAIN TO USE ANTI-SEIZE COMPOUND ON ALL FASTENERS!**

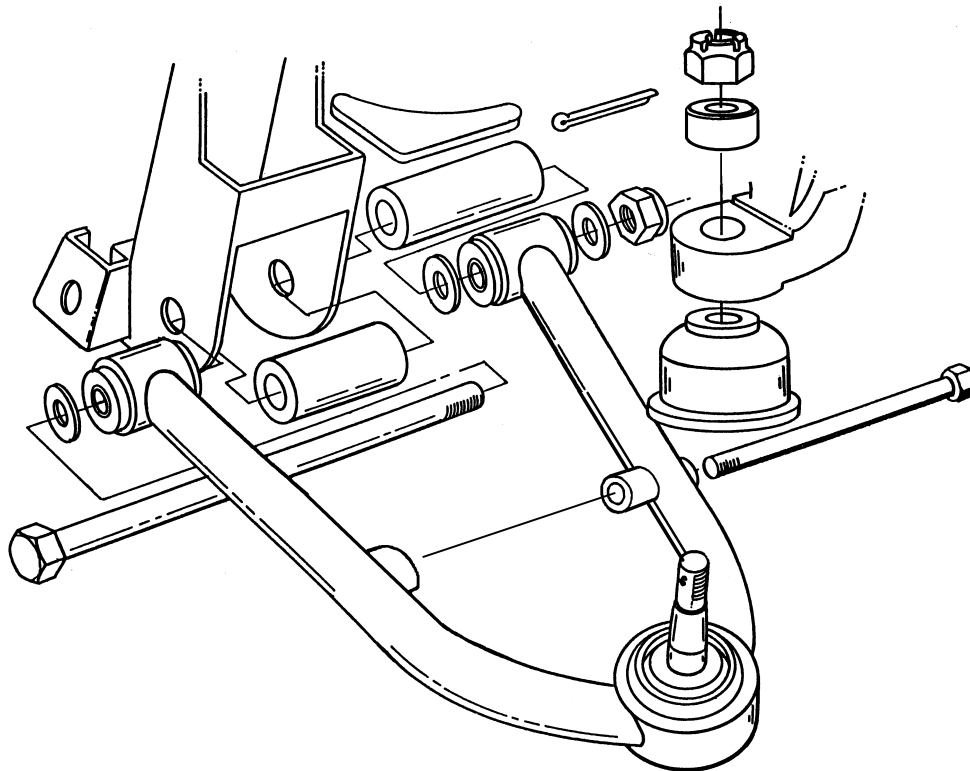

HEIDTS
HOT ROD & MUSCLE CAR PARTS