

INSTALLATION INSTRUCTIONS

1964-1/2 to 1970 MUSTANG

CROSSMEMBER KIT

Please read these instructions *completely*
before starting your installation.

Remember the basic rule for a successful installation:
Measure Twice, Weld Once!



Installation Instructions

1964-1/2 to 1970 Mustang Crossmember Kit

Start by supporting the car on 4 jack stands. Place the front jack stands under the frame rails at the firewall, as the front frame will be cut open and will be temporarily very weak. It may bend and not support the car. The car should be sitting on approximately the same angle as it does on the ground.

Remove all the old front suspension components. The shock towers will also be removed. See Figure 1 which shows the cut lines used to remove them. Draw the cut lines around the shock towers with a soapstone or other marker and cut them out. A plasma cutter works great here, but a torch or saber saw can be used. Cut them loose from the frame rails, also. *HEIDTS* has a panel filler kit, #PX-325, to enclose the openings. Remove the lower control arm mounts. When you are done, you should have clean, bare frame rails, ready for the next step.

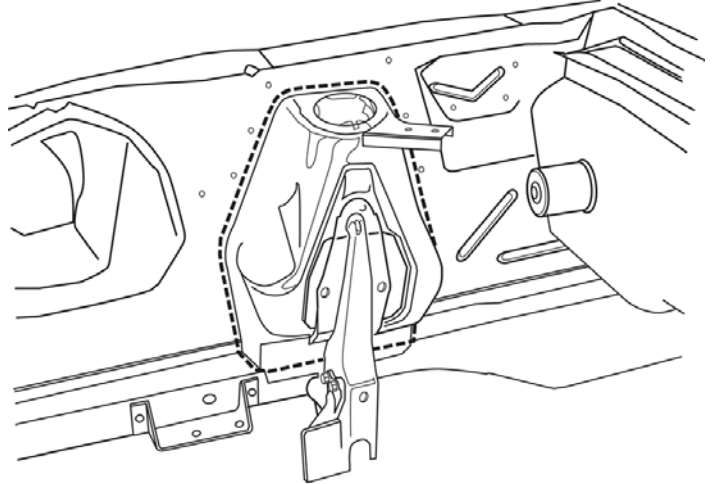

Figure 1

Trimming and boxing the rails is next. Figure 2 shows the notches for coil springs that need to be cut in the rails, along with removing the lower outer flange in the boxing plate area. Measure back 24-1/4" from the front surface of the front crossmember and scribe a centerline around the rails. This will be your spindle centerline. Next scribe the spring reliefs onto the rails. You can use the formed boxing plates as templates for the scribed lines. The spring relief radius is centered on the 24-1/4" scribe line. Just remember to cut enough material away to provide clearance for the radius in the outer boxing plates. Figure 2 shows how the boxing plates will completely enclose and strengthen the frame in this area. Grind or otherwise clean any rust from the rails, as the boxing plates should be welded to clean metal. The upper/inner formed boxing plates are placed on the rails and clamped securely. Tack weld them to the rails. Next clamp in place the outer boxing plates and tack weld them to the upper plates and to the frame. Lastly, clamp in place the lower plates. Tack weld them to the others. Remove the clamps and weld them to each other and to the frame. Weld short sections at a time in alternating locations to minimize warpage. You may grind the welds smooth when done.

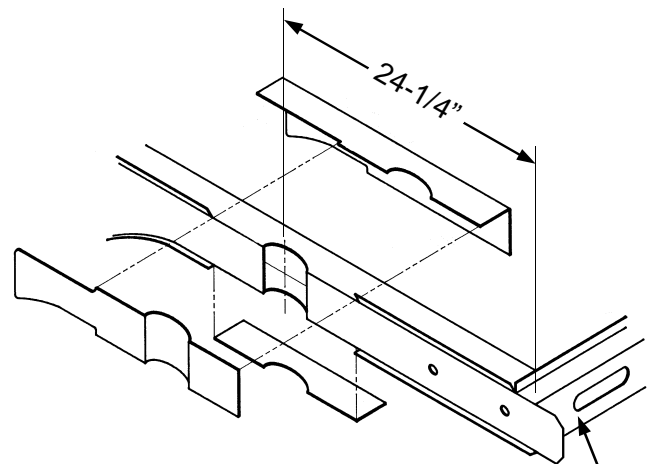

Figure 2

Measure from
Front Surface

Installation Instructions

1964-1/2 to 1970 Mustang Crossmember Kit

This kit is designed to use only full lower A-Arms. Stock lower control arm strut rods will not clear or mount to the frame rails. Begin by installing the Lower A-Arms onto the crossmember. Mount the Crossmember Spacers and the Rear Spacers which were supplied with the Lower Control Arms onto the Crossmember as shown in Figure 3 using the supplied Inner Bushing Bolts, Nuts and a temporary spacer under the Nuts. DO NOT use the A-Arms for this operation as the welding heat will melt the rubber bushings. Tighten the Bolts and Nuts tight. Weld the Rear Spacers to the Crossmember all around. Weld the Crossmember Spacers as far as possible inside the crossmember on both ends. Position the Gussets horizontally, not vertically, against the Rear Spacers and the back of the Crossmember. Weld Gussets to Spacers and Crossmember. When it cools, remove the bolt.

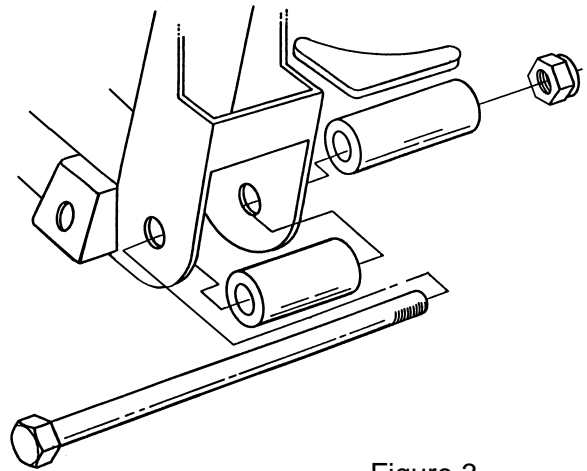

Figure 3

Now it is time to start fitting and installing the new crossmember. Slip the crossmember up into the frame, center it on the scribed axle center line. See Figure 4. If it does not fit, grind the sides of the crossmember until you can get the crossmember in place, as shown. Make sure the crossmember is fully seated on the underside of the actual lower boxing plate. Tack weld in place, check location, then weld in place, welding all around both ends, top, sides, and bottom.

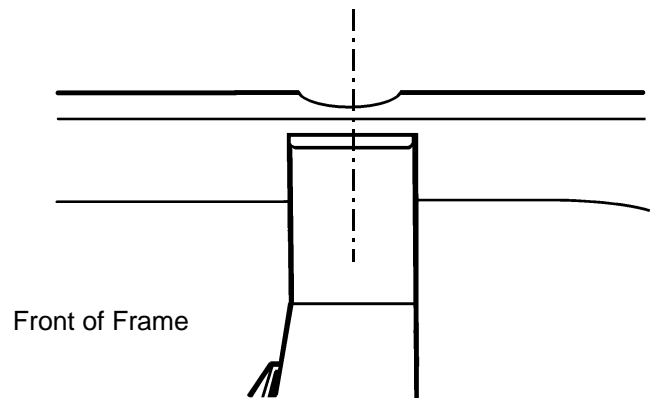

Figure 4

Next are the spring towers. They sit on top of the frame rails, and drop over the crossmember, as shown in Figure 5. They are higher in front, which is the anti-dive angle. Clamp in place and weld all around, including the outer gusset flanges on the outside of the rails. For added strength, you can also weld the inside of the gusset flanges.

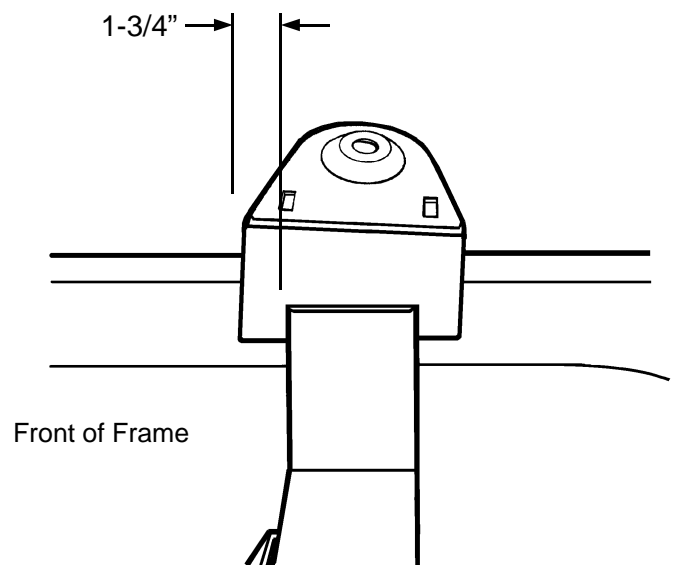

Figure 5

Installation Instructions

1964-1/2 to 1970 Mustang Crossmember Kit

That's all there is to it. Go ahead and finish the installation of the suspension components using their instructions. **Note:** The rack and pinion mounts will accept both Mustang II and later Mustang power rack and pinions. If you use a later unit, you must use an adapter kit from *HEIDTS* to space the rack out correctly. Also note that a **REAR SUMP OIL PAN** is required to clear the front crossmember and rack & pinion unit. **DO NOT** modify the rack & pinion mounts to relocate the rack to clear the pan, as that will ruin the geometry of the suspension and cause severe bump-steer. This also requires that this kit use 2" dropped spindles to position the car at stock ride height. After the rest of the car is assembled and back on the ground, do your front end alignment as follows:

Caster 1° positive
Camber 1/2° positive
Toe-In 1/8" ± 1/8"

Check the installation after 100 to 200 miles, including the alignment. The springs should have settled down by now, so the lower control arms are parallel to the ground. If the car still sits too high, you may need to change to softer springs, or you can cut up to one coil off the bottom of the springs to get the lower arms horizontal. If it sits too low, stiffer springs or *HEIDTS* new Spring Spacers are available. If you have any questions during or after the installation, feel free to call us for technical assistance.

