

Installation Instructions

Universal Crossmember Kit - 60" Track Width

Please read these instructions completely **BEFORE** starting your installation.

Remember the basic rule for a successful installation:

Measure Twice, Weld Once!

1. Begin your installation by locating the axle centerline of your vehicle. If you have the original suspension in place, then just transfer the centerline of the spindles with a vertical line onto the side of the frame rails. If the original suspension is gone, then the best way to do this is to stand a fender in place on the frame and stand the front wheel and tire in place in the fender. Now, slide a broom handle or tube straight through the wheel center. Mark a vertical line at the location where it contacts the frame. This will then place the spindle centerline in the center of the fender opening, right where you want it. Now that you know where the front-to-back spindle centerline is, measure the width of the frame at that point. The maximum standard frame width that will fit between the springs is about 33-1/2". If your frame is wider than that, it will need to be C-notched for the springs. If you still have the original suspension on the frame, remove it next.
2. Now you must determine the ride height of the front suspension, and actually of the entire car, as the frame must also be set at the correct rake that you intend the finished car to sit. Adjust the height of the frame, or the entire car, to this height, and then support the frame on jack stands with shims at this height. Now check the height of the spindle, again using your set-up wheel, compared to the height of the frame rail, at the axle centerline. Mark the actual spindle centerline height on the side of the frame rail (You may want to subtract 1/4" from the centerline location for flattening of the tires under pressure). If it comes through the wheel below the frame rail, then temporarily tape a piece of cardboard to the side of the rail to mark the centerline on. The bottom of the frame should be no lower than one inch below the spindle and the top not more than four inches above the spindle. As you see, you can adjust the ride height of your car within this range, if your frame is smaller than these dimensions (See Figure 1). You can also adjust the position of the crossmember, and the frame, with 2" Dropped Mustang II Spindles, if the frame does not fall within this range. Note that if the frame is more than 1/2" below the spindle, it will need to be C-notched for the rack boots, if you do not use dropped spindles. Also note that if you have a thicker frame, just slice a 12" long section off and box in the top of the frame for the spring tower and upper control arm clearance. The depth of this slice will be determined in a later step.
3. The front section of the frame needs to be boxed, from about 6" ahead of the spindle to around 18" behind it. The rear boxing is to reinforce the frame back as close to the firewall as possible, since the frame is just that much stronger in the front, where most of the stress is created.
4. If you purchased a complete I.F.S. Package from Heidt's, it was supplied with Full Lower A-Arms. Begin by installing the Spacers onto the crossmember. The holes where the lower control arms attach to the Crossmember must be enlarged to 5/8". Mount the Crossmember Spacers and the Rear Spacers which were supplied with the Lower Control Arms onto the Crossmember as shown in Figure 2 using the supplied Inner Bushing Bolts, Nuts and a temporary spacer under the Nuts. DO NOT use the A-Arms for this operation as the welding heat will melt the rubber bushings. Tighten the Bolts and Nuts tight. Weld the Rear Spacers to the Crossmember all around. Weld the Crossmember Spacers as far as possible inside the crossmember on both ends. Position the Gussets horizontally, not vertically, against the Rear Spacers and the back of the Crossmember. Weld Gussets to Spacers and Crossmember. When it cools, remove the bolt.
5. Now it is time to measure the crossmember for trimming. The inner width of your boxed frame rails will be the vertical cuts on the crossmember. The horizontal cuts are determined as follows: The lower control arm pivot bolts are 3-1/2" below the spindle centerline on the standard Mustang geometry. Measure down (or up) from your spindle centerline mark to the bottom of your frame rail. Subtract (or add) your dimension from 3-1/2" and the difference will be the dimension from the control arm inner bolts to the horizontal cuts on the crossmember. You will need to do this twice, 1-3/4" forward and rearward of the spindle centerline, as this is where the crossmember will actually contact the frame (See Figure 3). Also keep in mind that your frame is tapered and sitting on an angle, so the front and back cuts are almost never the same. Also remember that the crossmember should be level, both side to side and front to back.

6. Now transfer these dimensions to the actual crossmember. The rack mounts are on the front of it. Double check all your measurements, and then go ahead and cut the crossmember. It is always better to leave a little material on and grind it to fit nice and snug (it is easier to grind off than to add back on!). The crossmember is centered on the spindle centerline. When you have the crossmember in place, check it for level, then give it a couple of tack welds to hold it in place. Then verify that it is as high in the frame as you wanted. You can do this by temporarily assembling the lower control arms and spindles onto the crossmember. C-clamp a 2x4 under the crossmember with a couple of shims to support the control arms level and stand the spindles up on the ball joints. You can now verify the ride height exactly. If it is OK, then proceed. If not, then remove the crossmember, grind or add material and retack in place. It may look OK now, but the upper control arm mounts may require some adjustments in the positioning of the crossmember. Also, do not trim off the tops of the crossmember uprights yet, as they are used in another step.
7. The upper control arm mounts, or the spring towers are next. They are a little more complicated than the crossmember, so work carefully, and think out what you are doing completely. They are positioned 38-1/2" apart measured from the center of the shock cup holes. They are placed 1-1/2" forward of the front of the crossmember. The 1/8" off-set provides you with built-in caster. To position them at the proper height, use the tapered boxing plates as gages. Stand the plates on edge on top of the tops of the crossmember, up against your frame boxing plates, with the thick end towards the front (See Figure 4). This 3 degree taper is your anti-dive. Hold the spring towers against the outside of the frame so they line up with the gage plates and transfer the location of the frame top surface onto the spring towers. Again remember that the front and back will not be the same, so remember to transfer both front and back lines. Then hold the spring towers on top of the frame and at the 38-1/2" spread dimension. Take care to insure that they are not rotated, that the slots for the upper control arms are in line with each other from spring tower to spring tower. Mark the spring towers vertically from the outsides of the frame rails (See Figure 5). Also make sure that the surface with the two slots, where the upper control arms mount is flat to each other from tower to tower across the frame, and the spring mount cups are tilted slightly up. You could clamp a piece of bar or tubing onto the slotted surface from one spring tower to the other to keep them flat for this measurement.
8. Now go ahead and start to cut the spring towers to fit. This is the most difficult part, and may take a couple of cuts and some fitting. If your measurements show that the back of the spring towers need to be cut so it is thinner than 1", then you will either have to raise the entire crossmember and spring towers and reconsider the ride height you have selected, or slice off some of the top of the frame and box it in. You will need that 1" minimum height for clearance for the rear part of the upper control arm (See Figure 6). Note: it is OK to do this much major modification to a frame, as the frame that remains within the crossmember will still be plenty strong, and the nice ride you will have will be worth all the work.
9. Now tack weld the spring towers in place. Double check your measurements again. If all looks well, then trial assemble the upper control arms onto the spring towers and spindles, if you have left them on. If not, put them back on! The suspension in this position is the actual ride position when you are driving your car, if it is set up properly. With the upper control arms centered in their mounting slots, the spindles should be straight and square, with around 1 degree tilt rearward (caster). Also check that the spring towers line up with the tapered gage plates when they are stood on the tops of the crossmember uprights. They should be at their 3 degree anti-dive angle. If they do not line up or the spindles cannot be brought into position, the spring tower location may need to be adjusted. If everything lines up and the spindles are square, congratulations, as you are 90% done.
10. Next, trial fit the rack. If it clears the frame by 1/4" or so, then you are OK. If not, you will need to C- notch the frame for the rack. Use a piece of tubing or form a piece of leftover crossmember material to fit around the rack. Trial and error is the only way to determine how much to cut the frame. Just make sure to provide enough clearance around the rack boots for full suspension travel.
11. You should now have your complete set of Mustang parts installed, minus springs and shocks. If it appears that the springs will have enough clearance to the sides of the frame, then remove all the Mustang parts and weld all the crossmember parts in place. M.I.G. welding is more than adequate for this project. Trim down the gage plates to box in the open inner ends of the spring towers. You can now cap off the tops of the crossmember uprights, trimming them down shorter if necessary to look nice.

If you are using stock components, you will need to install strut rod brackets, part no. MP-003, purchased separately. Continue on to Step 12. If not, then you are finished and proceed on to the assembly and alignment of your suspension.

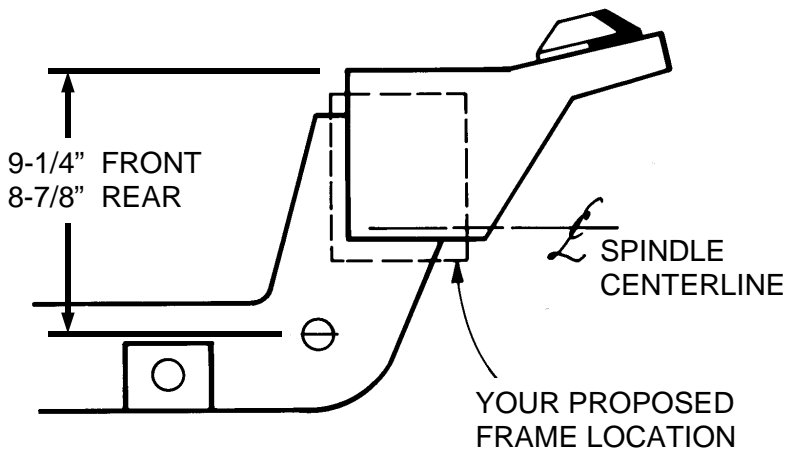

Figure 1

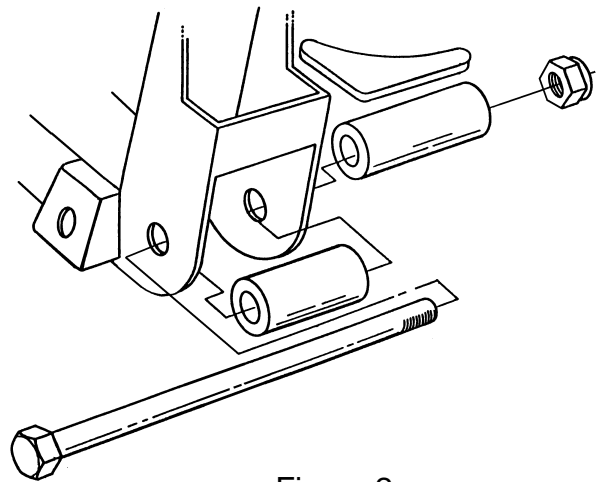
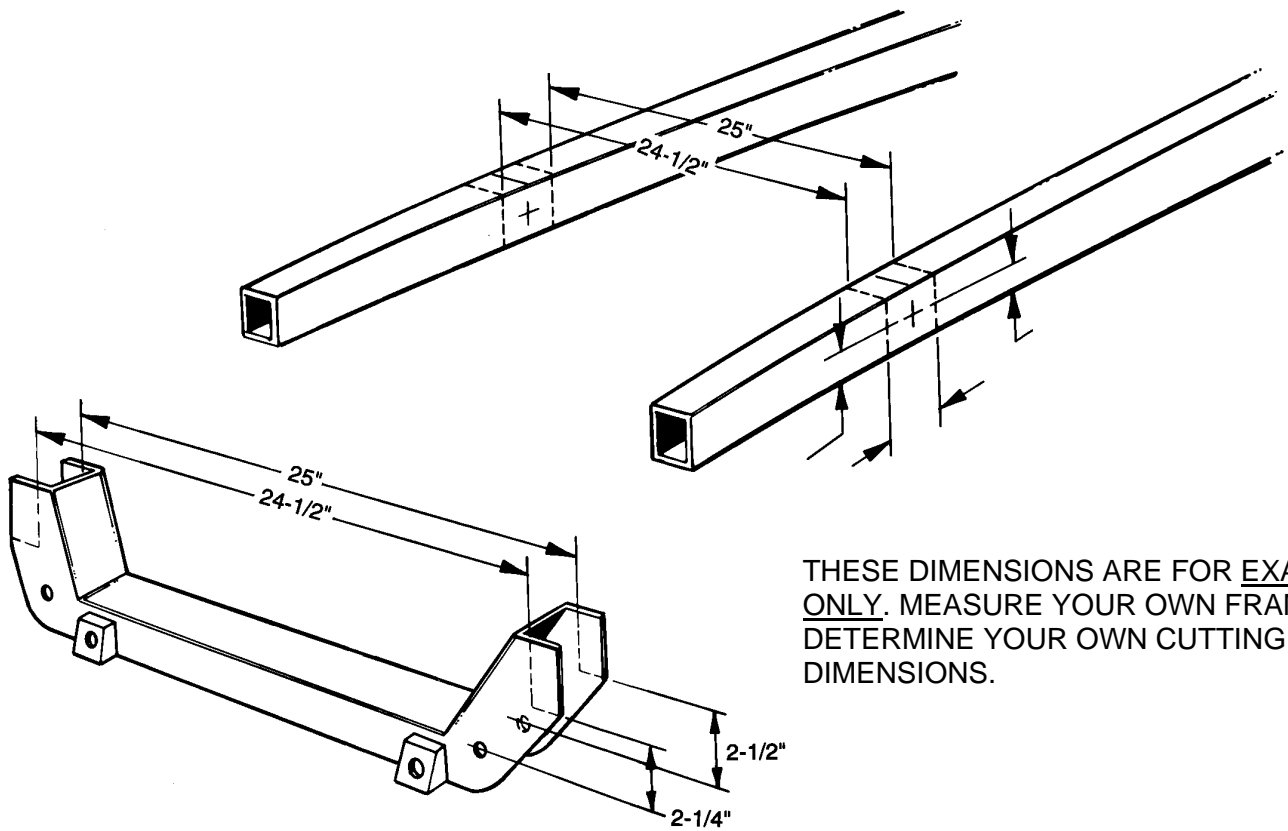

Figure 2



THESE DIMENSIONS ARE FOR EXAMPLE ONLY. MEASURE YOUR OWN FRAME TO DETERMINE YOUR OWN CUTTING DIMENSIONS.

Figure 3

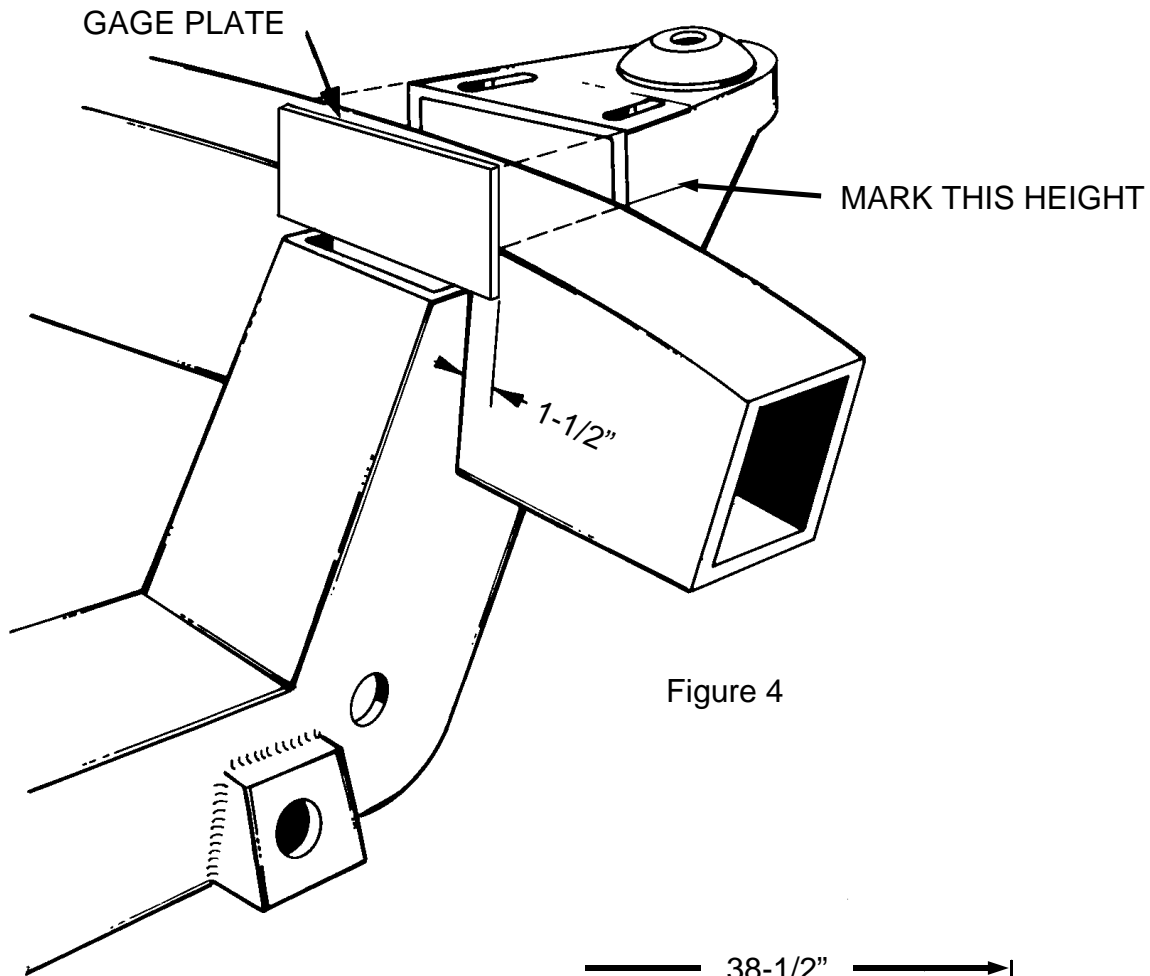

Figure 4

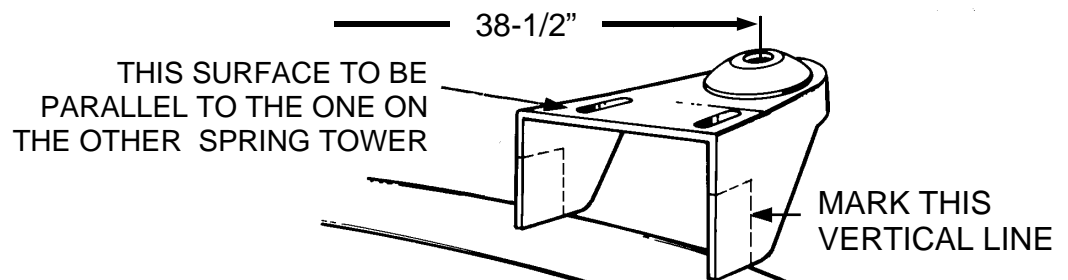
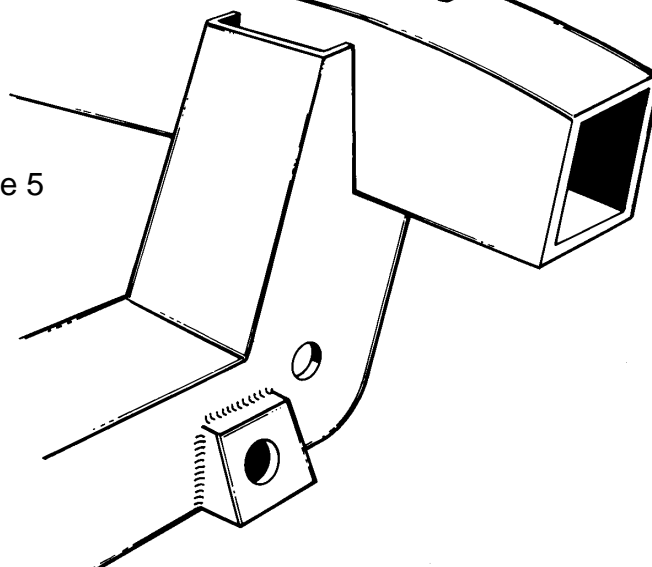

Figure 5



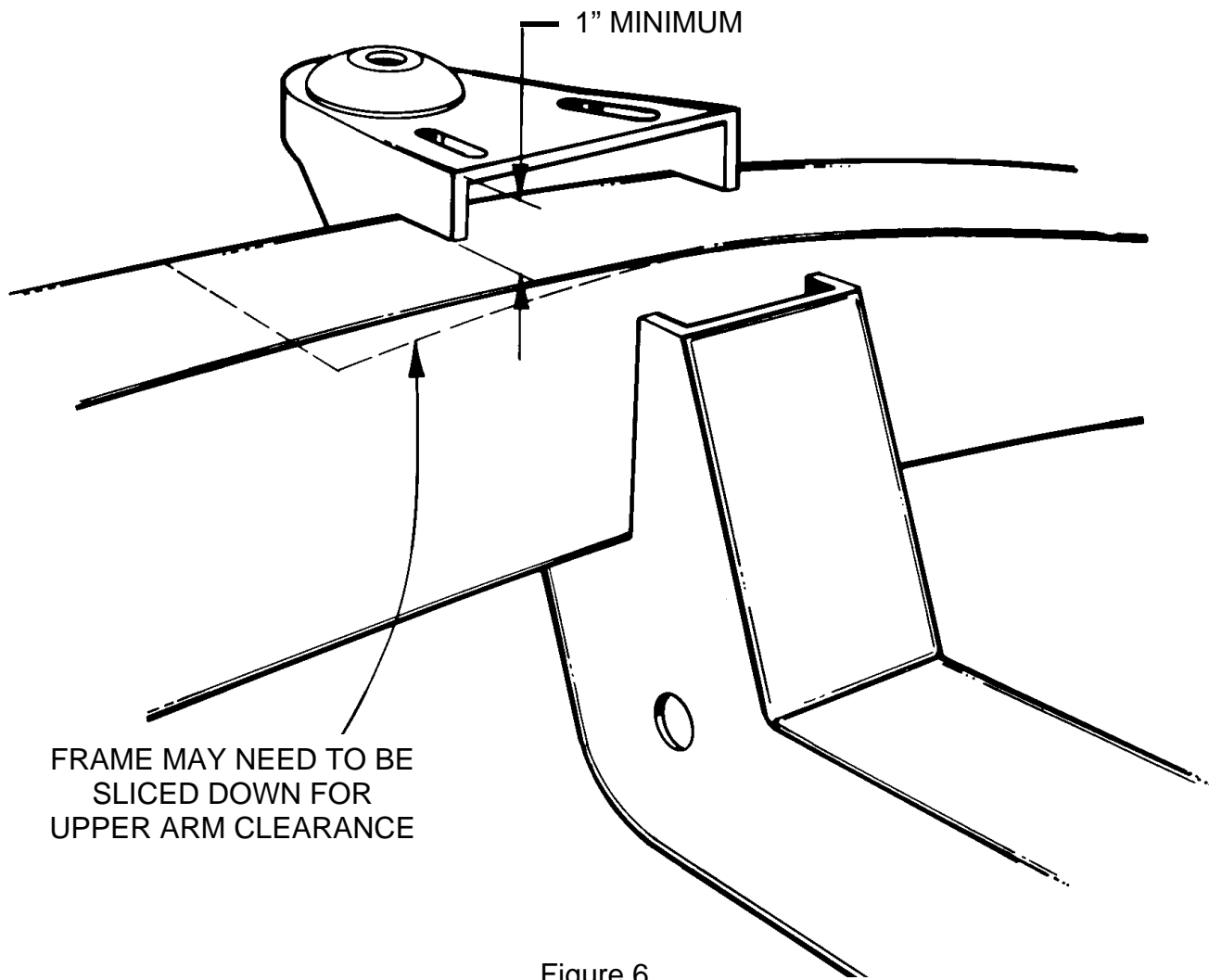

Figure 6

OPTIONAL STOCK STRUT ROD INSTALLATION

11. If you are using factory lower control arms and strut rods you will continue here. Use the lower control arm and strut rod for locating the rear strut rod supports and gussets. Using a 2 x 4 and a C-clamp, install the control arm as shown in Figure 7.

12. Install the strut rod onto the control arm. Now, assemble onto the strut rod the large rubber bushings, including the cupped washers, and the strut mount plate. Be certain to fully tighten the nut on the strut rod to its' fully seated position. (See Figure 8) There are two rubber bushing sets available; the standard replacement and the improved set. We recommend the improved set, as it provides more stability to the front suspension. The Pinto and Mustang strut rods are different lengths. We recommend the use of Pinto strut rods, as they are bent less than the Mustang strut rods. You will find that with either strut rod the strut rod plate does not line up with the bottom of the frame rail. The strut rod must be heated in the elbow area and bent outward. The rod is bent outward until the strut mounting plate lines up to the frame rail. You will find that because the Pinto strut rod is initially bent less and requires much less bending. The strut rod will act as an alignment fixture while you tack weld the mount plate in place, then tack weld the gusset in place. Remove the strut rod, bushings, and arm, and finish welding to the frame and each other.

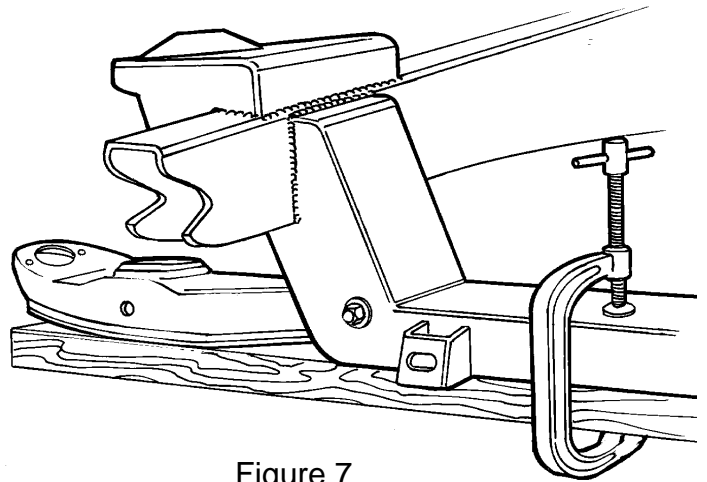

Figure 7

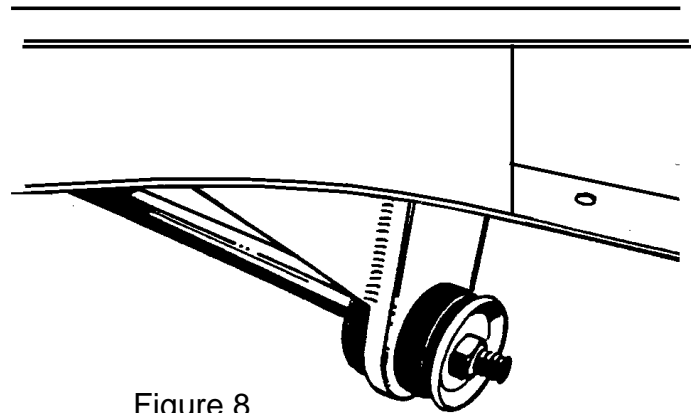

Figure 8

You can now install all the suspension components. Your final spring selection must position the suspension with the lower control arms level as before, with all the weight of the entire car on the suspension. You cannot do this final step until the car is near completion, so do not cut your springs down now, trying to get the bare frame to sit level, as you cannot add on to them when all the weight is put back on the car. You can fabricate some temporary struts to use in place of the springs and shocks if you need to roll the chassis around. The alignment specifications for your suspension are as follows:

Caster is 1° positive

Camber is 1/2° positive

Toe-in is 1/8"

Check the installation after 100 to 200 miles, including the alignment. The springs should have settled down by now, so the lower control arms are parallel to the ground. If the car still sits too high, you may need to change to softer springs, or you can cut up to one coil off the bottom of the springs to get the lower arms horizontal. HEIDTS Hot Rod Shop has a wide range of springs available. If it sits too low, stiffer springs or HEIDTS new Spring Spacers are available. If you have any questions during or after the installation, feel free to call us for technical assistance.

