

Installation Instructions

1954-1955 CHEVY PICK-UP REAR 4-BAR KIT

*Please read these instructions completely **BEFORE** starting your installation!*

Your HEIDTS Hot Rod Shop Rear 4-Bar Kit contains the following items:

- 2) Axle Brackets
- 2) Frame 4-Bar Brackets
- 4) Adjustable Link Bars
- 1) Upper Coil-Over Crossmember
- 1) Hardware Kit

1. Before removing the stock rear axle and springs, be sure to mark the location of the axle on the frame so you can locate the new rear axle in the same position to insure the wheels will be centered in the rear fender openings.

2. Remove the stock rear axle springs. Grind off the rivet heads from the front spring perches and remove the perches from the frame. Drill out the holes to 7/16" diameter.

3. Assemble the front brackets onto the frame with the 4-bar holes to the rear, using the 7/16-14 Grade 8 bolts and lock nuts supplied. Do not tighten until all the bolts are installed in the brackets.

4. Install the new crossmember into the frame with the main tube flush with the tops of the inside frame rail formed end brackets. Align the crossmember in the frame, aligning the top, front hole in the formed frame end bracket with the existing hole in the frame. The front surface of the crossmember should be located 31-3/4" back from the top hole on the 4-bar brackets, see Figure 1. If you do not have an existing hole in the top of your frame, position the crossmember as shown in Figure 1. The lower flanges go under the frame rail flanges, not inside the rails. See Figure 2. Drill the remaining 3/8" holes in the frame rails to match the end brackets. Fasten the crossmember to the frame using the 3/8-16X1" bolts and lock nuts provided.

5. Position the axle housing into the frame. Rotate the housing to set the pinion angle to match the angle of the engine, see Figure 3. The engine angle must be set at this point. Adjust the bars to equal length. Assemble the bars, with the adjusters to the front, and axle brackets onto the housing using the 5/8-18 bolts and lock nuts supplied. The center-to-center dimension of the brackets is 38-1/2". Make sure that both brackets are the same distance from the ends of the axle housing. The axle brackets should be tack welded to the housing, and the assembly double checked for square and correct pinion angle. Final welding should be performed by a qualified welder.

6. Finish assembling the axle housing. Pinion angle can be fine adjusted using the lower bars. Install the coil-over shocks onto the upper crossmember and axle housing brackets using the 5/8-11 bolts, lock nuts and spacers supplied.

7. A panhard rod is required. Install it onto the axle housing and position the frame bracket against the frame boxing plate. If the rear section of the frame over the axle housing is not boxed, a small boxing plate will need to be bolted or welded in place.



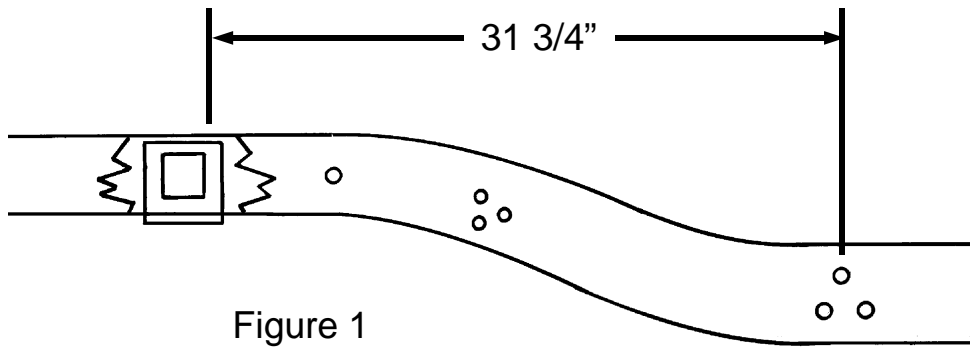
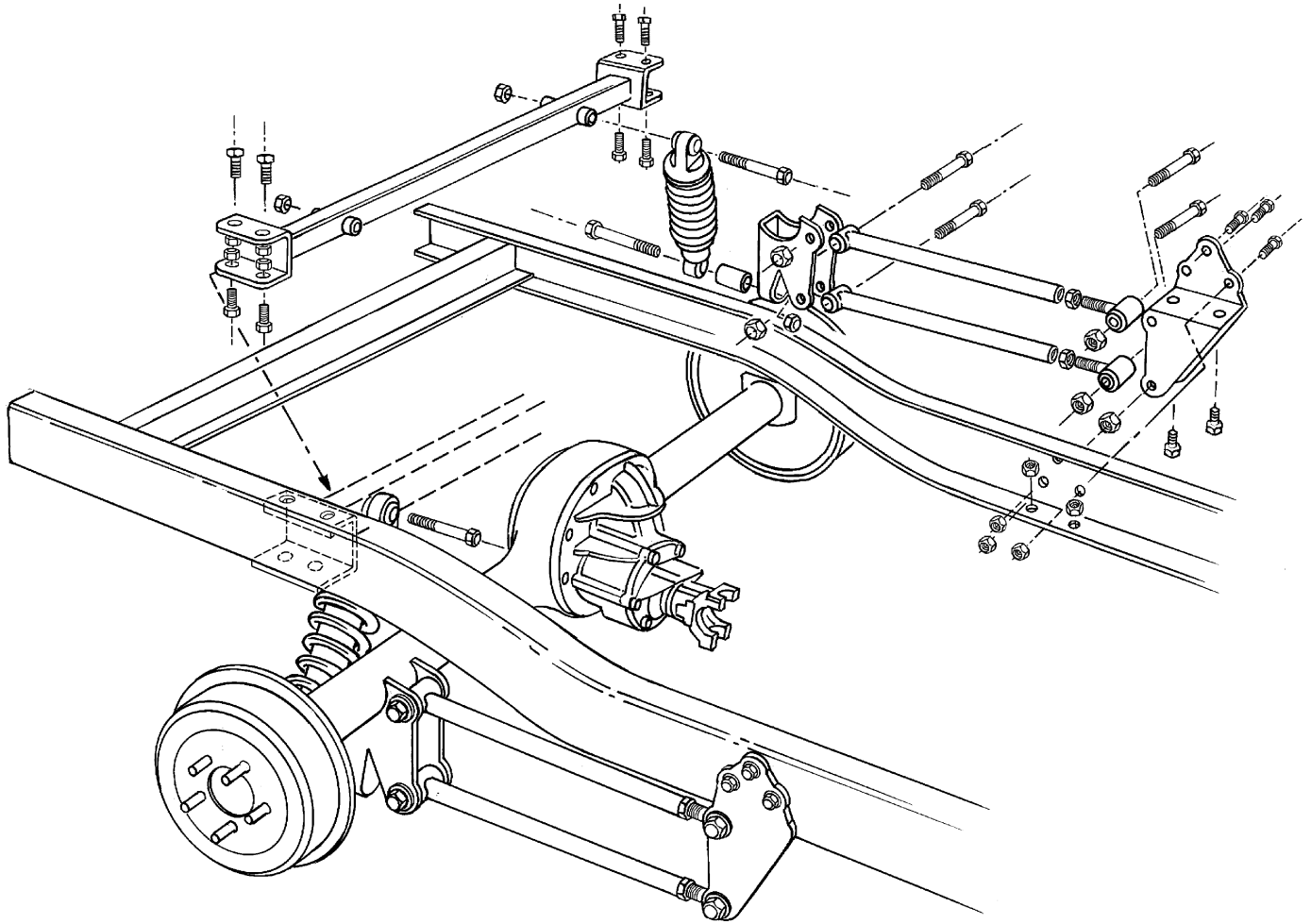

Figure 1

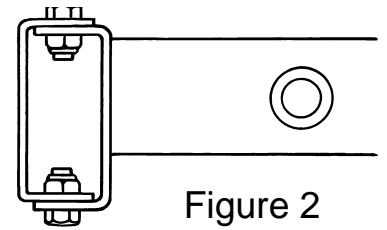

Figure 2

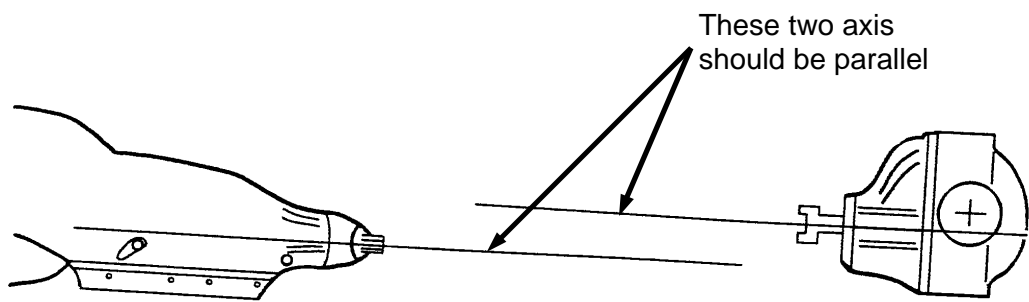

Figure 3