

Installation Instructions

DISC BRAKE CONVERSION BRACKET KIT

using 11" FORD ROTORS and GM CALIPERS

*Please read these instructions completely **BEFORE** starting your installation!*

Your HEIDTS Hot Rod Shop Disc Brake Conversion Kit contains the following items:

- 2) Brake Caliper Adapter Brackets-Left & Right
- 2) Long Caliper Mounting Bolts
- 2) Short Caliper Mounting Bolts
- 2) Caliper Adapter Spacers

This kit is designed to use `75-`80 Granada Rotors, `78-`88 GM Calipers and `74-`78 Mustang II Bearings & Seals

Begin your installation by mounting the Caliper Adapter Brackets onto the spindles using the Bolts and Spacers provided. Tighten the lower bolt first to insure the Brackets are square to the spindles, then tighten the upper bolts. Loctite on these bolts is highly recommended. Pack the bearings with a high quality wheel bearing grease, and install the inner bearings into the rotors, followed by the supplied grease seals using an installation tool or a block of wood. Do not hammer directly on the seals. Install the rotors onto the spindles, followed by the outer bearings and the spindle nut washers. Adjust the bearing preload as normal. The rotors may slightly contact the upper part of the spindles. File or grind a small flat on the spindles for clearance. Install the cotter pins and dust caps. Install the calipers next, with the bleeders pointing up. Use only correct caliper mounting bolts. Install new brake lines and bleed the system as normal. NOTE: If you are using stock lower control arms, the outer lip may need to be ground off a small amount as it may contact the rotor surface.

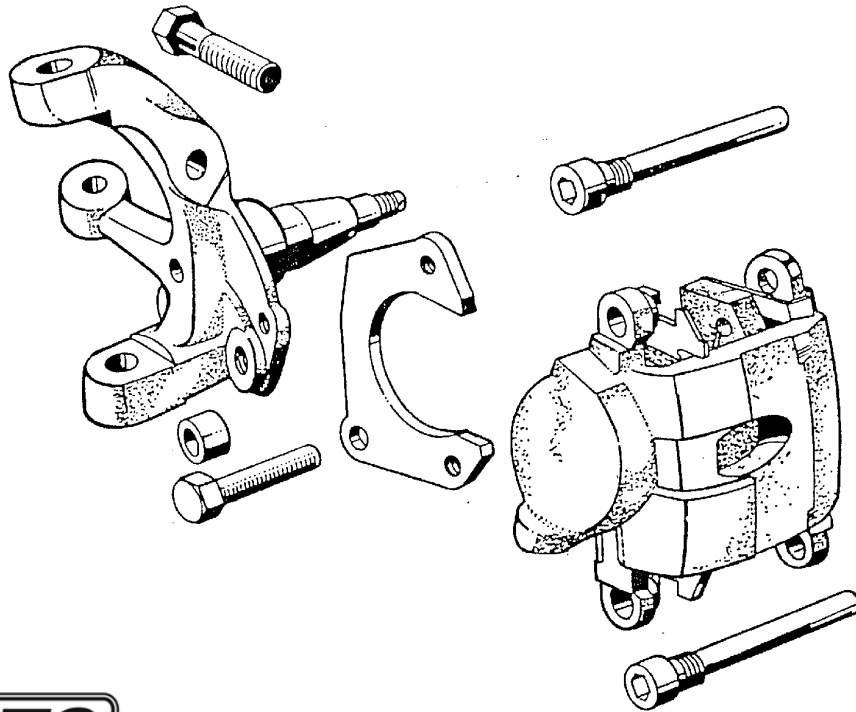

HEIDTS
HOT ROD & MUSCLE CAR PARTS