

# Installation Instructions

## 1940 to 1948 Chevy Crossmember Kit

Please read these instructions completely  
**BEFORE** starting your installation.  
Remember the basic rule for a successful installation:  
**Measure Twice, Weld Once**

1. Start by supporting the car on 4 jack stands. The car should be sitting on approximately the same angle as it does on the ground, or slightly lower in front.

2. Unbolt and remove the entire old front suspension assembly from the car, including the crossmember. On the frame rails there is a hole on the top and bottom of each frame rail under the old front suspension crossmember. Using the center of these holes, make a mark on the frame 1/2" back. Now scribe those mark lines completely around the frame rails. Those scribed lines are the axle centerline for the new crossmember. See Figure 1.

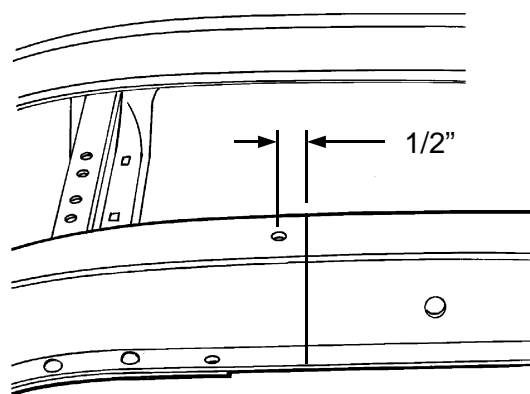

Front of Frame Figure 1

3. The flange on the inside of the frame rails must be trimmed away in the area of the new center crossmember. Trim off the flange for a 3-3/4" length, 1-7/8" in front and 1-7/8" in back of the centerline mark. See Figure 2

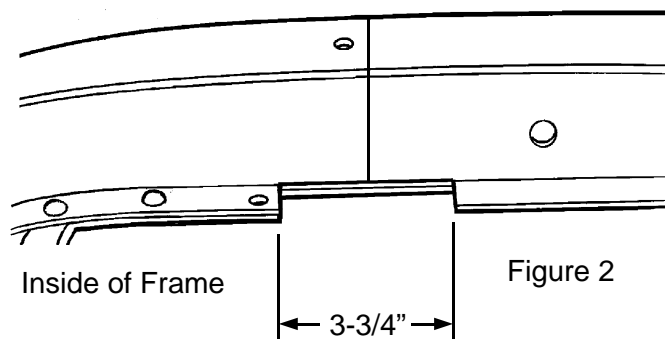

Inside of Frame Figure 2

# Installation Instructions

## 1940 to 1948 Chevy Crossmember Kit

4. If you purchased a complete I.F.S. Package from *HEIDTS*, it was supplied with Full Lower A-Arms. Begin by installing the Spacers onto the crossmember. The holes where the lower control arms attach to the Crossmember must be enlarged to 5/8". Install the Crossmember Spacers and the Rear Spacers which were supplied with the Lower Control Arms onto the Crossmember as shown in Figure 3 using the supplied Inner Bushing Bolts, Nuts and a temporary spacer under the Nuts. DO NOT use the A-Arms for this operation as the welding heat will melt the rubber bushings. Tighten the Bolts and Nuts tight. Weld the Rear Spacers to the Crossmember all around. Weld the Crossmember Spacers as far as possible inside the crossmember on both ends. Position the Gussets horizontally, not vertically, against the Rear Spacers and the back of the Crossmember. Weld Gussets to Spacers and Crossmember. When it cools, remove the bolt.

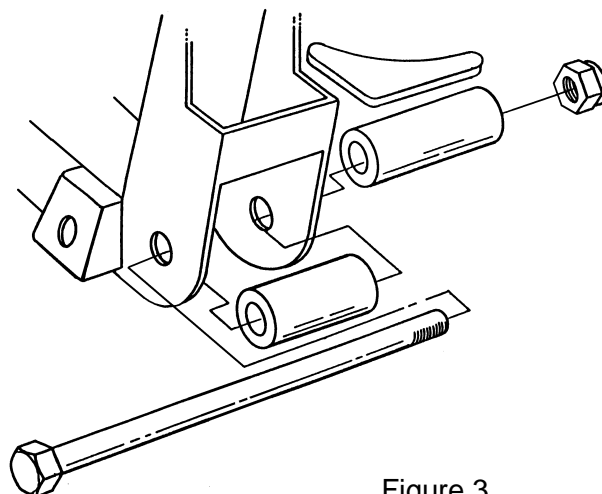

Figure 3

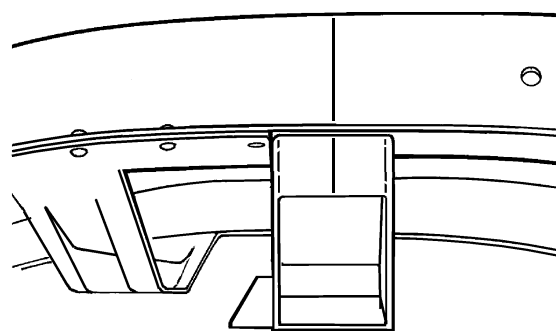

Figure 4

5. Next slip the crossmember up into the frame, center it on the scribed axle center line (Figure 4). If it does not fit, grind the sides of the crossmember until you can get the crossmember in place, as shown. Make sure the crossmember is seated fully on the underside of the actual frame lower surface and not the remaining flange of the old front crossmember section you trimmed out. Figure 6 shows this clearly. Tack weld in place, check location, then weld in place, welding all around both ends, top, sides, and bottom.

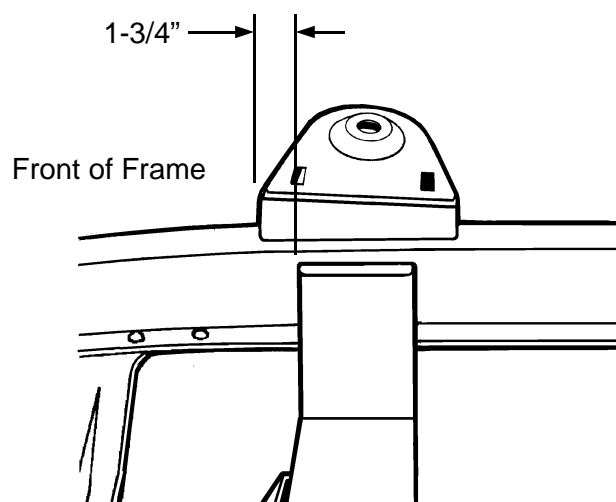

Figure 5

6. Next are the spring towers. They sit on top of the frame rails, and are located with the higher side towards the front as shown in Figure 5, (1-3/4" forward of the crossmember). Clamp in place, double check your dimensions, then weld all around, including the gusset flanges on the sides of the rails. For added strength, you can also weld the inside of the gusset flanges.

# Installation Instructions

## 1940 to 1948 Chevy Crossmember Kit

If you are using factory components, you will need to install strut rod brackets, purchased separately, part no. MP-003. Continue on to Step 7. If not, then you are finished and proceed on to the assembly and alignment of your suspension.

### OPTIONAL STOCK STRUT ROD INSTALLATION

7. If you are using factory lower control arms and strut rods you will continue here. Use the lower control arm and strut rod for locating the rear strut rod supports and gussets. Using a 2 x 4 and a C-clamp, install the control arm as shown in Figure 8.

8. Install the strut rod onto the control arm. Now, assemble onto the strut rod the large rubber bushings, including the cupped washers, and the strut mount plate. Be certain to fully tighten the nut on the strut rod to its' fully seated position. (See Figure 6) There are two rubber bushing sets available; the standard replacement and the improved set. We recommend the improved set, as it provides more stability to the front suspension. The Pinto and Mustang strut rods are different lengths. We recommend the use of Pinto strut rods, as they are bent less than the Mustang strut rods. You will find that with either strut rod the strut rod plate does not line up with the bottom of the frame rail. The strut rod must be heated in the elbow area and bent outward. The rod is bent outward until the strut mounting plate lines up to the frame rail. You will find that because the Pinto strut rod is initially bent less and requires much less bending. Before welding the strut rod mounts to the frame, install the two reinforcement plates on the underside of the frame as shown in Figure 8. Position the plates so the strut rod mounts and gussets are approximately centered on them. Weld in place, all around.

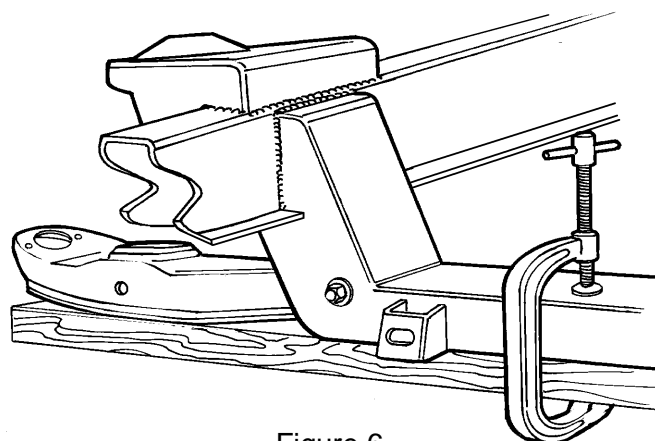

Figure 6



Figure 8

# Installation Instructions

## 1940 to 1948 Chevy Crossmember Kit

9. The strut rod will act as an alignment fixture. Tack weld the mount plate in place, then tack weld the gusset in place. Remove the strut rod, bushings, and arm, and finish welding to the frame and each other.

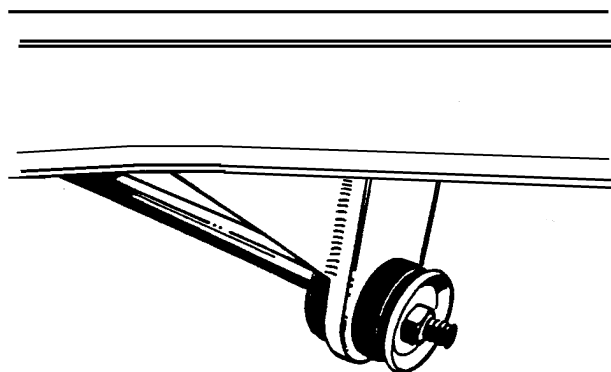

Figure 19

That's all there is to it. We suggest that, at this point, you trial install the steering rack to insure that you trimmed enough off of the stock crossmember. If it doesn't fit at this point, note where the interference is and trim a little at a time until it goes in. The power steering rack is slightly larger than the manual and often requires careful fitting in the gearbox area. Go ahead and finish the assembly of the Pinto parts. After the rest of the car is assembled and back on the ground, do your front end alignment as follows:

Caster 1° positive  
Camber 1/2° positive  
Toe-In 1/8" ± 1/8"

Check the installation after 100 to 200 miles, including the alignment. The springs should have settled down by now, so the lower control arms are parallel to the ground. If the car still sits too high, you may need to change to softer springs, or you can cut up to one coil off the bottom of the springs to get the lower arms horizontal. If it sits too low, stiffer springs or *HEIDTS* new Spring Spacers are available. If you have any questions during or after the installation, feel free to call us for technical assistance.

