

Installation Instructions

1934-1935 Chevy Standard Crossmember Kit

Please read these instructions completely **BEFORE** starting your installation.

Remember the basic rule for a successful installation:

Measure Twice, Weld Once!

1. Start by supporting the car on 4 jack stands. The car should be sitting on approximately the same angle as it does on the ground, or slightly lower in front.
2. Remove all the old suspension components from the frame. Also remove the rear shackle mounts which are riveted to the bottom of the frame.
3. Remove the stock radiator support crossmember. A temporary brace can be tack welded across the front part of the frame rails or bolted to the bumper mounts to hold the rails in place. If the motor is left in place, make sure the weight of the motor on the mounts does not spread or twist the rails when the stock crossmember is removed.
4. A pair of small boxing plates will need to be fabricated and installed in the front section of the frame as shown in Figure 1. Next, scribe a line around the frame rails, as shown, at 18-5/8" from the front. **NOTE:** Due to mid-year changes Chevy made it is suggested you verify that this is actually the spindle centerline on your frame. The inner lower flange of the frame should be trimmed back to the 1-7/8" dimension shown in Figure 1 or it can be removed entirely.
5. If you purchased a complete I.F.S. Package from *HEIDTS*, it was supplied with Full Lower A-Arms. Begin by installing the Spacers onto the crossmember. The holes where the lower control arms attach to the Crossmember must be enlarged to 5/8". Mount the Crossmember Spacers and the Rear Spacers which were supplied with the Lower Control Arms onto the Crossmember as shown in Figure 2 using the supplied Inner Bushing Bolts, Nuts and a temporary spacer under the Nuts. **DO NOT** use the A-Arms for this operation as the welding heat will melt the rubber bushings. Tighten the Bolts and Nuts tight. Weld the Rear Spacers to the Crossmember all around. Weld the Crossmember Spacers as far as possible inside the crossmember on both ends. Position the Gussets horizontally, not vertically, against the Rear Spacers and the back of the Crossmember. Weld Gussets to Spacers and Crossmember. When it cools, remove the bolt.
6. Now it is time to install the new crossmember. Slip it into the frame, center it on the scribed axle center line Figure 3. If it does not fit, grind the sides of the crossmember until you can get the crossmember in place, as shown. Make sure the crossmember is seated fully on the underside of the frame. Tack weld in place, check location, then weld in place, welding all around both ends, top, sides, and bottom.
7. Next are the spring towers. They sit on top of the frame rails, and are located as shown in Figure 4, 1-3/4" forward of the crossmember measuring from the front of the crossmember to the front of the spring tower. The higher side of the spring tower goes towards the front of the frame. Clamp in place, double check your dimensions, then weld all around, including the flanges down the sides of the rails. For added strength, you can also weld the inside of the flanges.
8. The radiator support is the last item. Center the support on the front of the crossmember and clamp or tack in place. Measure up from the top of the support to the top of the frame directly above the radiator perch, using a straight edge across the top of the frame rails. That dimension should measure 3-5/8", as shown in Figure 5. If it is too high and the dimension is less than 3-5/8", trim the base of the radiator support to bring it down to that dimension. Also check the clearance to the steering rack if any trimming is done to the radiator support. If the support is low, the radiator cradle assembly can be shimmed up to its correct position when it is bolted to the radiator support. Please note that this model car does not accept the power rack and pinion rack without serious modifications to the factory Ford geometry design, due to the much larger pinion housing and hydraulic lines, as they interfere with the stock radiator cradle. Power steering is absolutely not recommended for this car even if it would fit. The light front end weight, compared to a Mustang II, coupled with the extra ease of power steering, will cause you to lose the feel of the car on the highway.

If you are using stock components, you will need to install strut rod brackets, part no. MP-003-1, purchased separately. Continue on to Step 9. If not, then you are finished and proceed on to the assembly and alignment of your suspension.

Installation Instructions

1934-1935 Chevy Standard Crossmember Kit

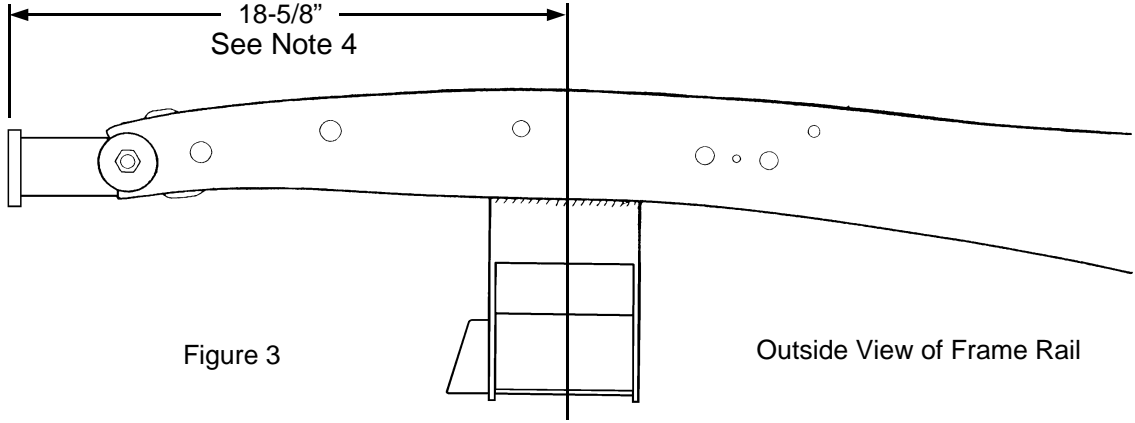
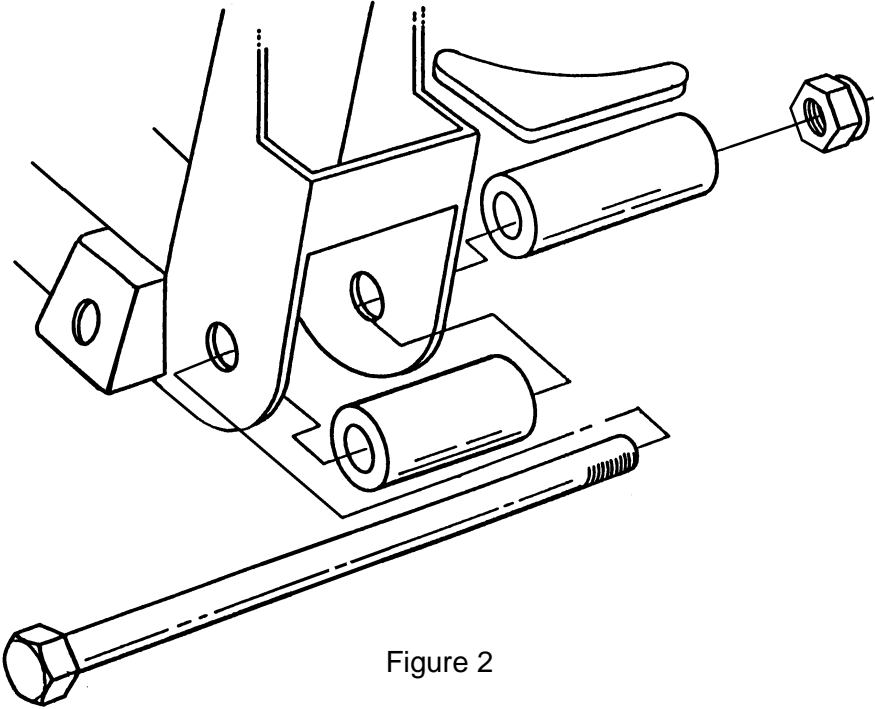
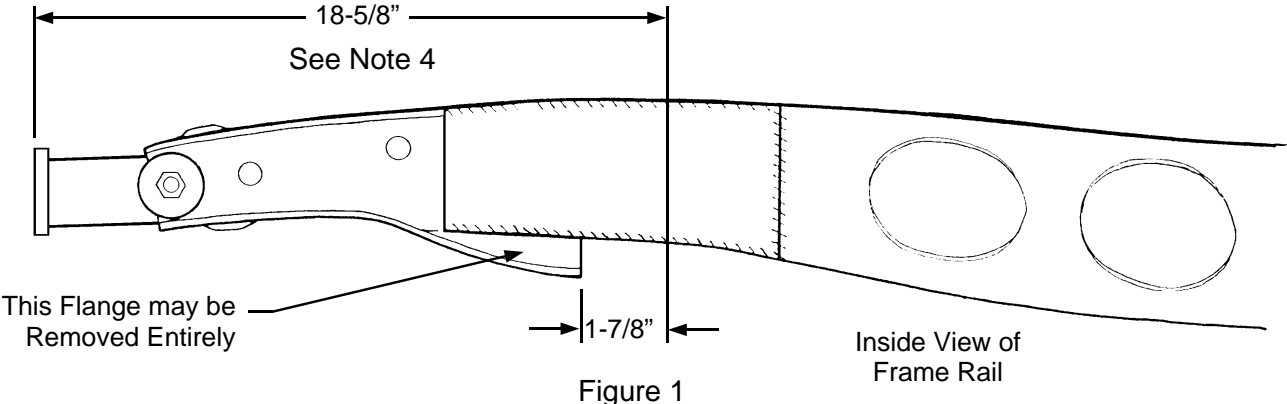

Installation Instructions

1934-1935 Chevy Standard Crossmember Kit

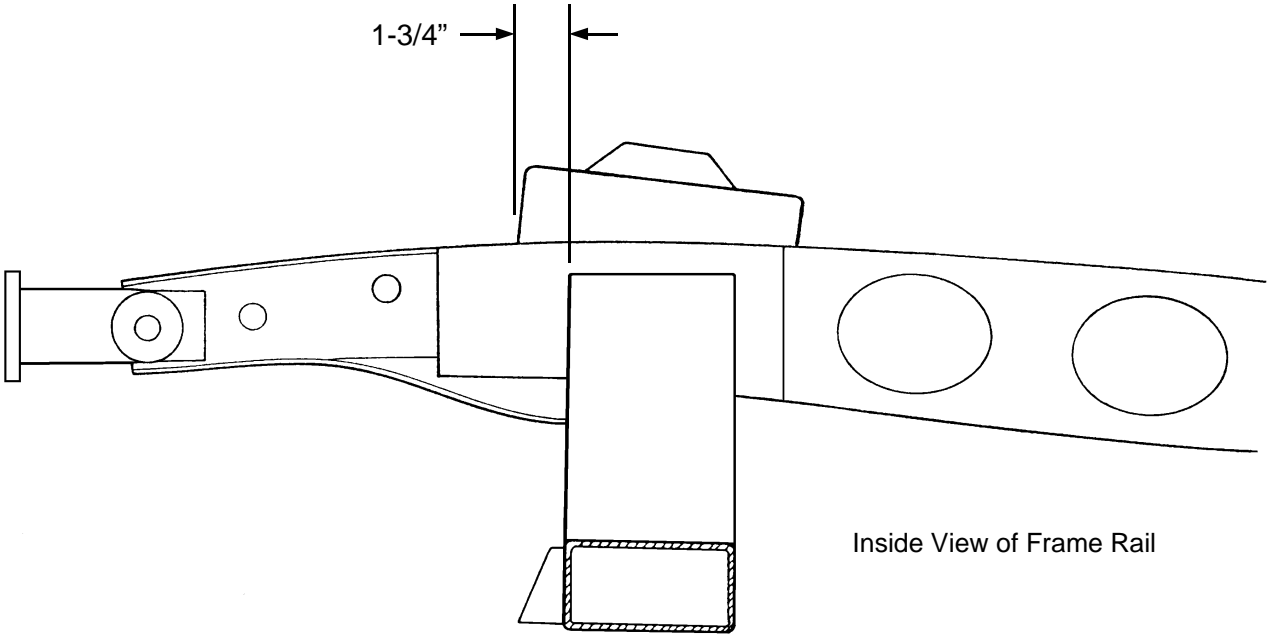

Figure 4

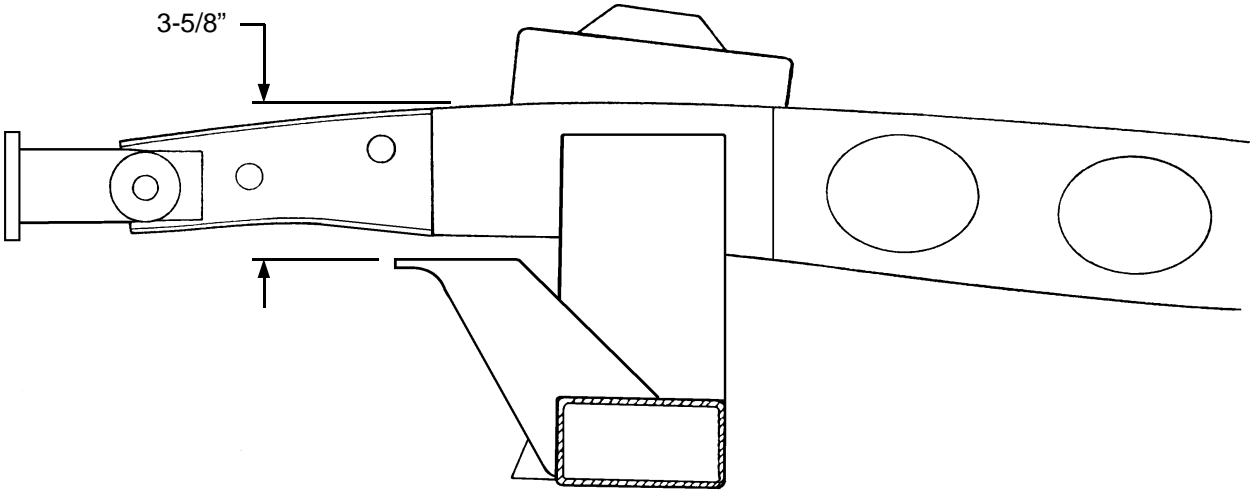

Figure 5

Installation Instructions

1934-1935 Chevy Standard Crossmember Kit

OPTIONAL STOCK STRUT ROD INSTALLATION

9. If you are using factory lower control arms and strut rods you will continue here. Use the lower control arm and strut rod for locating the rear strut rod supports and gussets. Using a 2 x 4 and a C-clamp, install the control arm as shown in Figure 6.

10. Install the strut rod onto the control arm. Now, assemble onto the strut rod the large rubber bushings, including the cupped washers, and the strut mount plate. Be certain to fully tighten the nut on the strut rod to its' fully seated position. See Figure 7. There are two rubber bushing sets available; the standard replacement and the improved set. We recommend the improved set, as it provides more stability to the front suspension. The Pinto and Mustang strut rods are different lengths. We recommend the use of Pinto strut rods, as they are bent less than the Mustang strut rods. You will find that with either strut rod the strut rod plate does not line up with the bottom of the frame rail. The strut rod must be heated in the elbow area and bent outward. The rod is bent outward until the strut mounting plate lines up to the frame rail. You will find that because the Pinto strut rod is initially bent less and requires much less bending. The strut rod will act as an alignment fixture while you tack weld the mount plate in place, then tack weld the gusset in place. Remove the strut rod, bushings, and arm, and finish welding to the frame and each other.

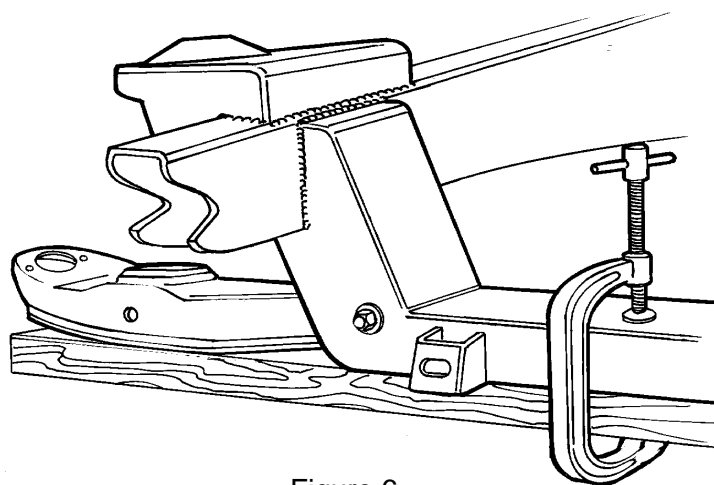

Figure 6

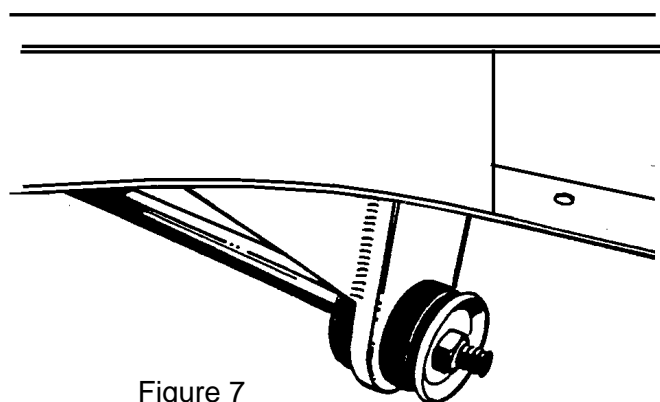

Figure 7

That's all there is to it. Go ahead and finish the assembly of the rest of the suspension components. After the rest of the car is assembled and back on the ground, do your front end alignment as follows:

Caster 1° positive
Camber 1/2° positive
Toe-In 1/8" ± 1/8"

Check the installation after 100 to 200 miles, including the alignment. The springs should have settled down by now, so the lower control arms are parallel to the ground. If the car still sits too high, you may need to change to softer springs, or you can cut up to one coil off the bottom of the springs to get the lower arms horizontal. If it sits too low, stiffer springs or *HEIDTS* new Spring Spacers are available. If you have any questions during or after the installation, feel free to call us for technical assistance.

