



SUPERIDE

INSTALLATION INSTRUCTIONS 1934-1935 CHEVY STANDARD INDEPENDENT FRONT SUSPENSION

Please read these instructions *completely*
Before starting your installation.
Remember the basic rule for a successful installation:
Measure Twice, Weld Once.

For questions on installations please call 800-841-8188 In Illinois (847) 487-0150



You are about to install your **HEIDTS** suspension system. You are probably wondering how complicated installing a complete IFS system really is, with all those pieces, all the angles, anti-dive, geometry... Don't worry. The HEIDTS IFS kits are designed so all that is taken care of for you. Just follow the instructions step by step and in a very short time your car will be sitting on the nicest riding IFS kit available.

Your car may be using stock frame rails or you may be using new reproduction boxed rails. If you are using new boxed rails, you may skip to **Step 4**. If you are using stock rails, you can proceed from here.

1. First, remove all the stock components. Any suspension brackets, radiator, steering or shock brackets that are welded to the frame should be taken off and ground smooth.
2. The stock crossmember will need to be removed next. In order to hold the rails in place, a temporary brace can be clamped or tack welded across the rails. Drill out the rivets and remove the crossmember. The rivet holes can then be welded up and ground smooth.
3. The front section of the frame should be boxed with a small pair of boxing plates, as shown in **Figure 1**. The rails should be squared up as far as the flanges are concerned and made straight and true. The boxing plates are then laid up against the rails and clamped in place. Weld short sections at a time to minimize warpage. Grind smooth when done.
4. Now, mark the axle centerline. Scribe a line around the frame rail at 18 5/8" from the front. See **Figure 1**. Repeat for both rails. This line represents the axle centerline.
5. Trial fit the new crossmember onto the rails. It should be located with its centerline 1/8" forward of the marked axle centerline. See **Figure 2**. The caster setting will bring the spindle pin back in line. During boxing, the rails may have a tendency to bow outward slightly if they were clamped ahead of the axle centerline. Pull the rails in to fit the crossmember up onto the rails. It should be seated flat against the bottom of the frame rails. Clamp in place, double check your measurements, making sure the crossmember is squared to the frame, then weld in place. Weld all around, top, sides and bottom. This crossmember keeps the front frame rails from twisting and flexing, so good strong welds are required.
6. The radiator support bracket is next. Center the support on the front of the crossmember and clamp in place. Measure up from the top of the support to the top of the frame directly above the radiator support, using a straight edge across the top of the frame rails. This dimension should measure 3 5/8". See **Figure 3**. If it is too high and the dimension is less than 3 5/8", trim the base of the radiator support to bring it to that dimension. If the support is too low, the radiator cradle assembly can be shimmed to its correct position when it is bolted to the radiator support.
7. Now assemble all the suspension components. **Note:** The shim washers supplied may be needed to center the calipers on the rotors. Do not install the coil-over assemblies just yet. Position the car at approximately the ride angle or rake the car will sit at when finished. Prop up the lower control arms so the center of the lower ball joint housing is 3/4" above the centerline of the inner pivot bolt. This is the designed midpoint of the suspension system. Now set the caster, camber and toe in. The settings are as follows:

CASTER 1° positive

CAMBER 1/4° positive

TOE-IN 1/8" +/- 1/8"

The caster and camber settings are done with the adjusters in the upper control arms. Both adjusters are screwed in or out an equal amount to change the camber, and they are adjusted opposite each other to change the caster. Approximately 1° of caster is built into the crossmember already, so not much change is required there. The interesting thing about the caster setting is that you can experiment with different settings and actually "tune" the characteristics of the handling of your car to your driving style. 1° of caster will give a nice road feel and good low speed drivability. 2° or 3° will yield better high speed stability and tracking, putting a better self-centering characteristic in the steering wheel, but will tend to start to make parking slightly more difficult. Have fun with this one, as it truly makes your car your own car. Just be sure that both sides have equal caster settings, or the car will tend to pull to one side.

For questions on installations please call 800-841-8188 In Illinois (847) 487-0150



8. Next, relax the suspension and install the coilovers. The spring seat rings should be in the bottom position, providing the least amount of preload. The car should now be placed on the ground. The spring seat rings should be adjusted to position the ride height of the suspension to that same 3/4" dimension referred to in Step 7. Make sure that at this point you are working with a finished, fully weighted car, not just a frame, or a frame and body. At this point do a quick double check of your alignment.

9. Since you are now at the point where you have a finished, running car (we hope!) it is time to test drive it. After a few hundred miles, double check the ride height and alignment. The springs may have settled, which would change the camber setting. Readjust the ride height before changing the alignment. After this initial settling period, the springs and bushings should have pretty much taken their final set, so you should be on your way to many miles of cruising in style, independently.

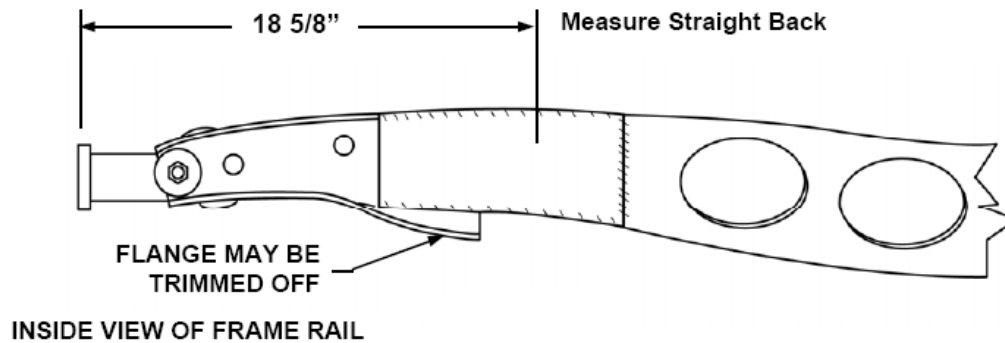

Figure 1- Boxing Frame & Axle Centerline

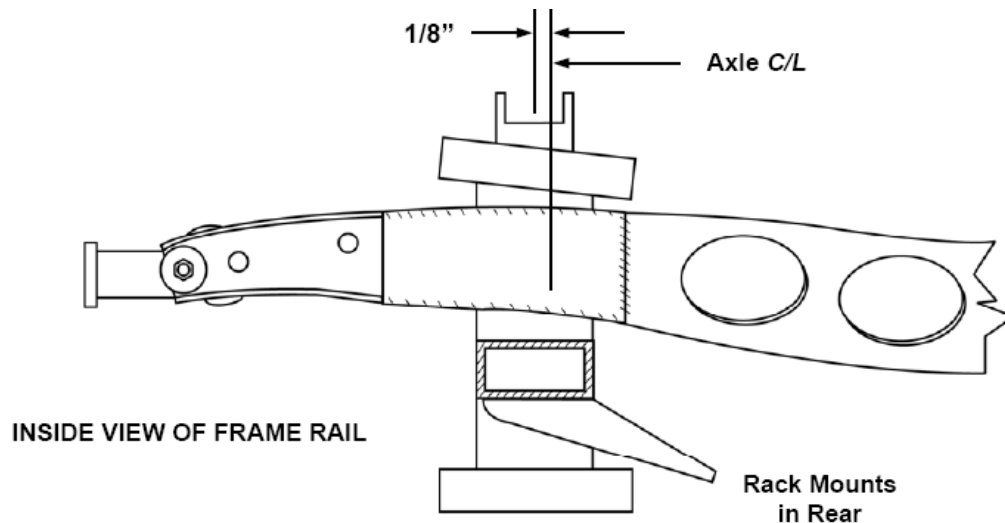

Figure 2- Crossmember Fitment

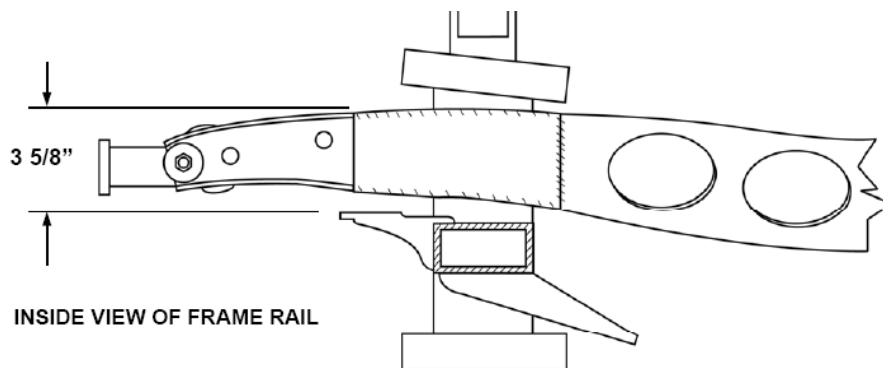

Figure 3- Radiator Support Bracket Install

For questions on installations please call 800-841-8188 In Illinois (847) 487-0150

