

HEIDT'S

INSTALLATION INSTRUCTIONS 1967-1969 CAMARO REAR 4-LINK KIT

Please read these instructions *completely*
before starting your installation.
Remember the basic rule for a successful installation:
Measure Twice, Weld Once.

HEIDT'S

Hot Rod Shop, Inc.

Start your installation by removing the rear seat. The reinforcement plates for the upper 4-link brackets are bolted in under the rear seat.

Jack up the car and support it on sturdy jack stands. Remove the drive shaft, e-brakes cables and rear axle assembly including leaf springs and shocks. If the brakes will be reused, the lines can be left connected to the backing plates depending on what type of axle will be used. Remove the rear section of the exhaust system. Also remove the front leaf spring mounts, as they will be modified and reused.

First remove the bump stop mounts from the frame. Install the top crossmember up into the frame rails under the floor, see Figure 1. The crossmember locates using the holes from the bump stop brackets. Note: If you have a 1967, the crossmember is located 18-3/4" from the back of the crossmember saddle brackets to the center of the rear shackle hole. Position it there and bolt in place, including the bump stop brackets. The U-channel must be firmly seated against the bottom of the subframe rail. Drill the 1/2" dia. holes through the factory frame rails using the crossmember end plates as templates and bolt securely in place.

Install the upper link brackets next. They locate using the front holes on the ends of the top crossmember plates on the front factory frame rails. Drill thru the floor and using the doubler plates inside the car, under the seat, sandwich the floor pan and bolt in place. Then drill 1/2" holes thru the factory frame rails and bolt the sides of the front mounts using the reinforcement plates in the inner side of the rails. See Figure 1.

The holes in the existing factory front leaf spring mounts need to be drilled out to 5/8" dia. for the front 4-link bolts. Once they are drilled, they can be installed and bolted back in place. See Figure 4.

If you purchased a complete rear axle housing with the brackets all ready installed, you can install it now. If you are installing the brackets on your own housing, the coil-over brackets are located 43-1/4" apart. They are centered equal distance from the outer ends of the housing, not from the center of the third member or pinion yoke. See Figure 2. The pinion angle should also be set with a 2° down angle(see figure 3). The panhard bar bracket is located on the left coil-over bracket locating against the coil-over bracket, positioned at 90° as shown in Figure 3. You can then fine tune the pinion angle to match your engine with the lower links.

Install the link bars with the adjusters to the rear into the mounts in the subframe connectors. Position the rear axle housing in place and install the bars into the brackets on the housing. Use the 5/8-18 bolts and nuts included. Assemble the coil springs onto the shock assemblies and install them into the upper mounts using the 5/8-18 x 2-3/4" bolts and nuts, and onto the housing using the 5/8-11 x 7" bolts, spacers and nuts supplied. Now install the Panhard Bar using the 1/2-13 bolts and nuts supplied. Adjust the Panhard Bar to center the housing. Adjust the link bars. The upper bars will position the housing, and the lower ones will set the pinion angle. See Figure 4.

Double check the pinion angle and fine tune the lower bars to set it. Install the bump stop rubbers onto the crossmember mounts. Connect the brake lines and bleed the brakes and then install the drive shaft and emergency brake cables.

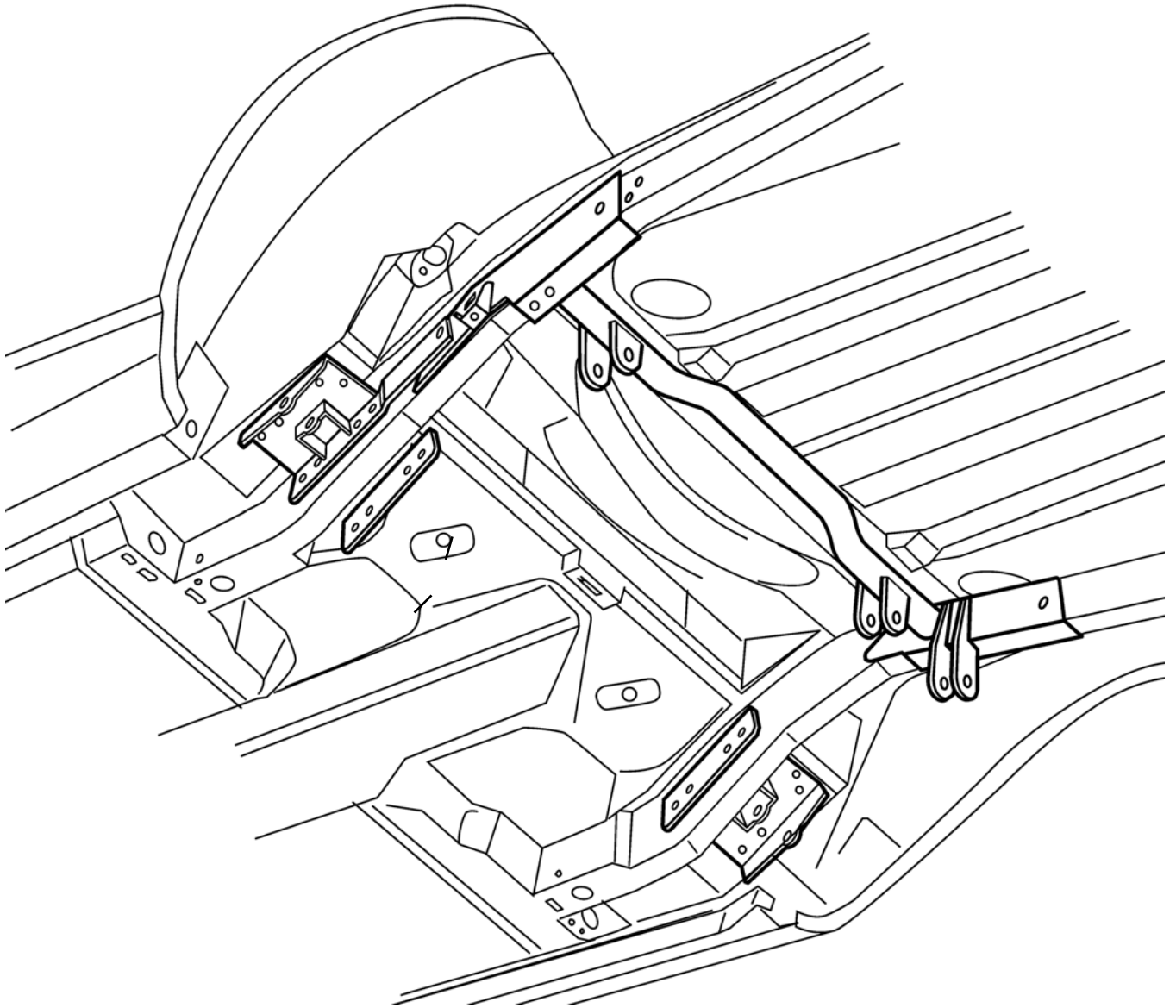

Figure 1

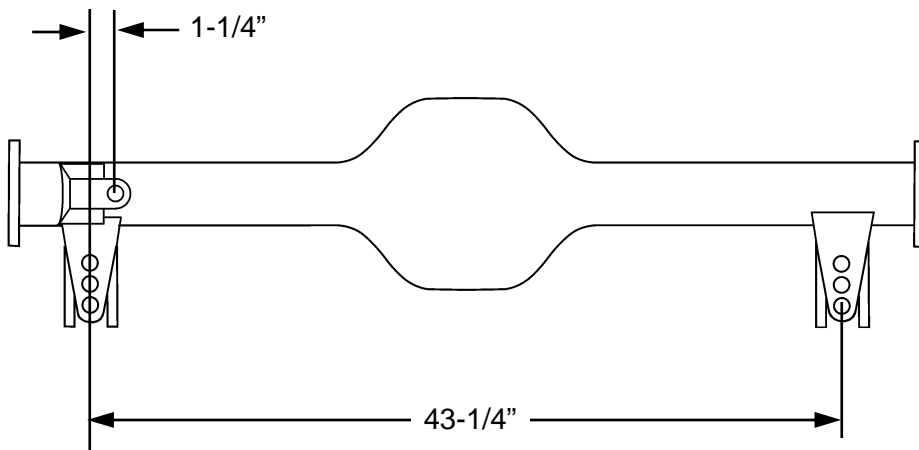

Figure 2

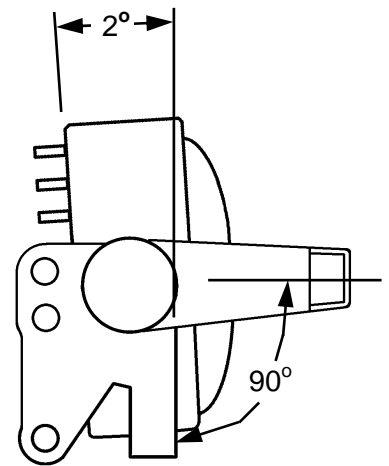

Figure 3

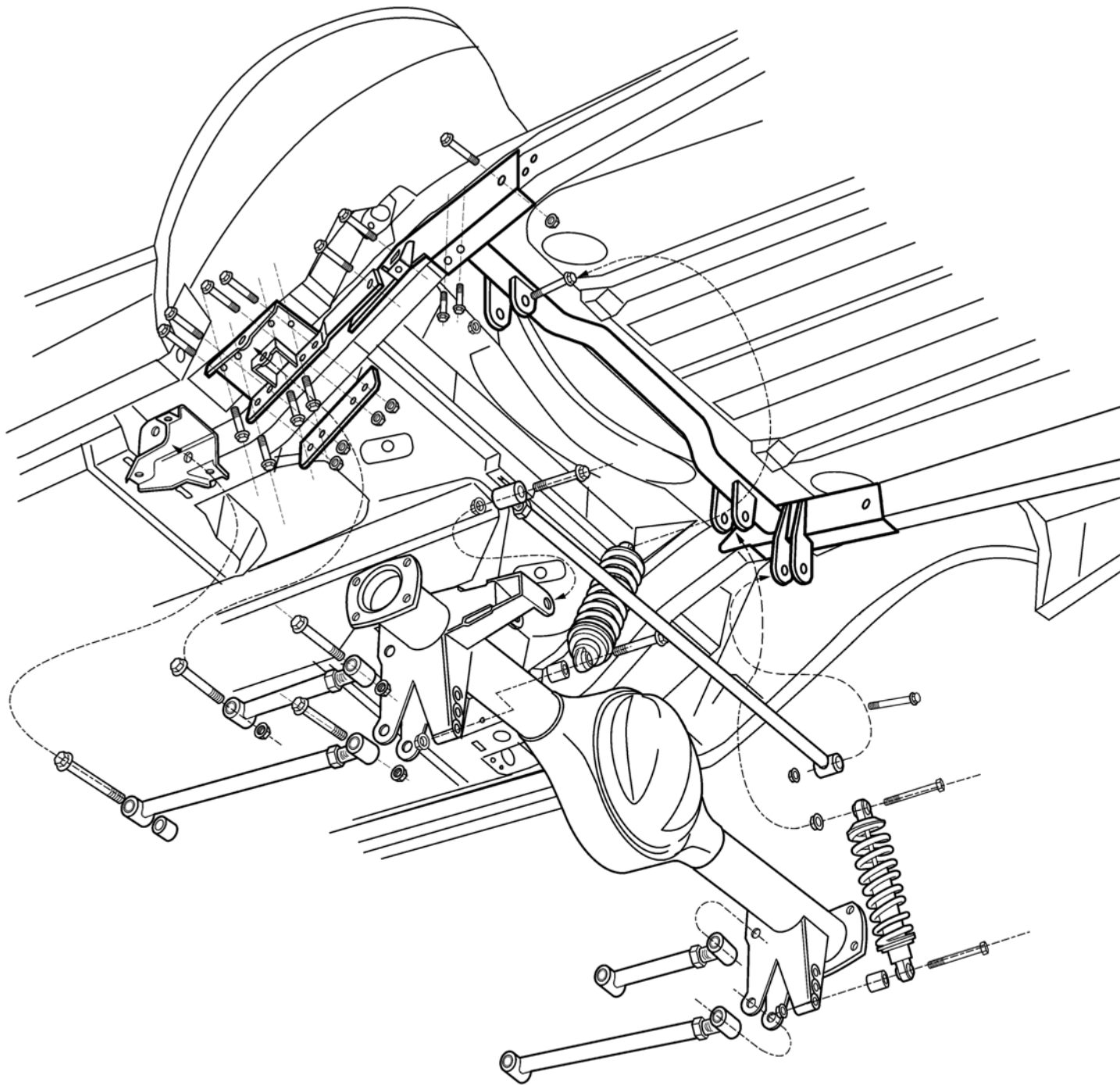

Figure 4

HEIDT'S

Hot Rod Shop, Inc.

© Heidt's Hot Rod Shop, Inc. 2006

1-800-841-8188 Illinois (847) 487-0150

Rev. 12-20-2007

IN-135